

CT100

Ticket Printing Scale

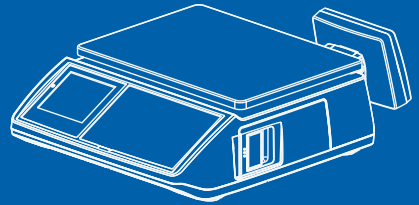

CAS

CONTENTS

PRECAUTIONS	4
PREFACE	6
CHANGING THE PRINTER ROLL	7
NAME AND FUNCTIONS	8
I. SAELS MODE	14
<i>Chapter 1 Basic Operation</i>	16
<i>Chapter 2 Sales for Weighed item</i>	23
<i>Chapter 3 Sales for non-weighed item</i>	24
<i>Chapter 4 Clerk Operation</i>	28
<i>Chapter 5 Discount & Payment</i>	39
<i>Chapter 6 Sales Transactions Simulation</i>	48
II. PROGRAM MODE	54
<i>Chapter 7 PLU Programming</i>	58
<i>Chapter 8 Report</i>	63
<i>Chapter 9 SET 1 (Discount, Barcode & HW Setting)</i>	70
<i>Chapter 10 SET 2 (Date, Time & Default Setting)</i>	81
<i>Chapter 11 Options (Receipt Formatting)</i>	85
<i>Chapter 12 Clerk</i>	94
<i>Chapter 13 Logo</i>	98
<i>Chapter 14 Tax Rate Group</i>	101
<i>Chapter 15 Test</i>	104
CODE [MS 1250 Windows Central Europe]	107
CODE [MS 1251 Window Cyrillic(Slavic)]	108
CODE [MS 1252 Window Latin-1]	109
CODE [MS 1253 Windows Greek]	110
CODE [MS 1254 Windows Turkish]	111
CODE [MS 1257 Windows Baltic]	112
CODE [FARSI FONT(IRAN)]	113
ERROR MESSAGES	114
SPECIFICATION	115
TABLE LIST	116
CASH DRAWER INTERFACE DRAWING	117
RS232C Interface Drawing	117
PROGRAM MENU MAP	118

PRECAUTIONS

Warning

Precautions when installing the scale. To ensure that you get the most from your scale, please follow these instruction.

Do not disassemble the scale.

When any damage or defect occurs, contact your CAS authorized dealer immediately for proper repair.



Do not overload beyond the maximum weight limit.

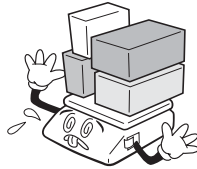

Scale must be grounded to minimize electricity static.

This will minimize defect or electric shock.



Do not pull the plug by its cord when unplugging.

Damaged cord could cause electric shock or fire.



To prevent from fire occurring, Do not place or use the scale near flammable or corrosive gas.



To reduce electric shock or incorrect reading, Do not spill water on the scale or place it in humid condition.

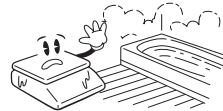

Avoid placing the scale near heater or in direct sunlight.

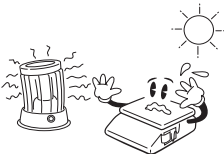

Insert plug firmly to wall outlet to prevent electric shock.

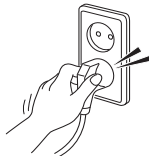

Use proper Adapter.

Incorrect adapter could damage the scale.

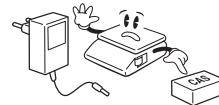

Attention

Make sure to plug your scal into the proper power outlet. For maximum performance, plug into a power outlet 30 minutes before the usage for warm up.

For consistent and accurate reading, maintain periodical check by your CAS authorized dealer.

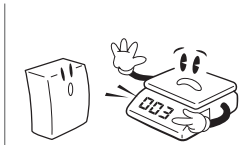

Avoid sudden shock to the scale.



Grab on the bottom of the scale when moving.

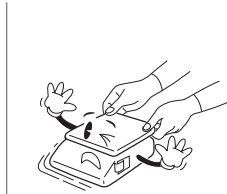

Take the battery out when scale is not in use for long time. Leakage from the batteries is hazardous.

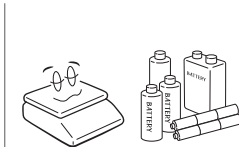

Place the scale on firm and temperature consistent environment.



By adjusting 4 corners of the scale, set the scale even using the built in scale leveling indicator.



Keep the scale away from other electromagnetic generating devices.

This may interfere with accurate reading.



PREFACE

Thank you for purchasing your CT100.

CAS scales are designed and produced under rigid quality control to deliver outstanding performance, reliability and long life.

This manual will help you with the proper operation and care of your new CT100.

Please review the CT100 manual before you use the scale and keep it handy for future reference.

- The Pb battery of product may not be fully charged. It is recommended to charge Li-ion battery using AC power before initial usage.

CHANGING THE PRINTER ROLL

- Recommended size for thermal paper;
58mm (Width) / 65 m(Thickness) / 60mm (Maximum Diameter)

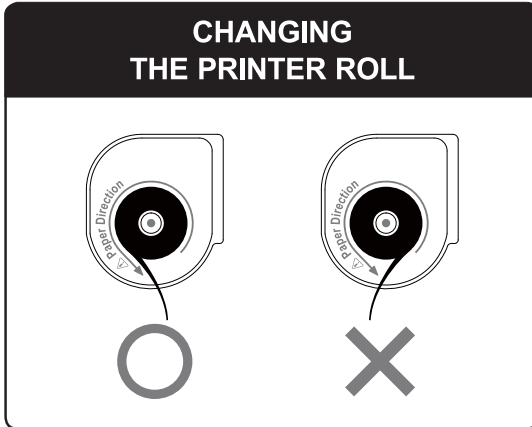

- It is recommended to tear off the ticket left to right.

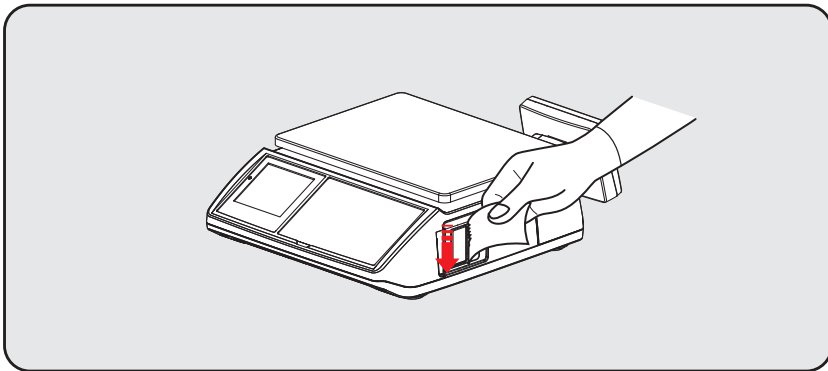

NAME AND FUNCTIONS

OVERALL VIEW

■ B TYPE

CT100-B

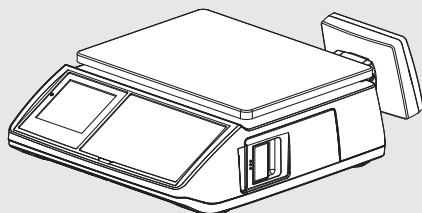

■ P TYPE

CT100-P

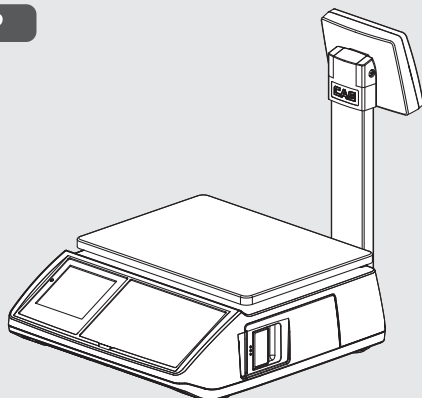

■ POLE TYPE INSTALLATIONS

- Insert the post pipe into a post bracket.
- Insert and fasten the display assembly screws.

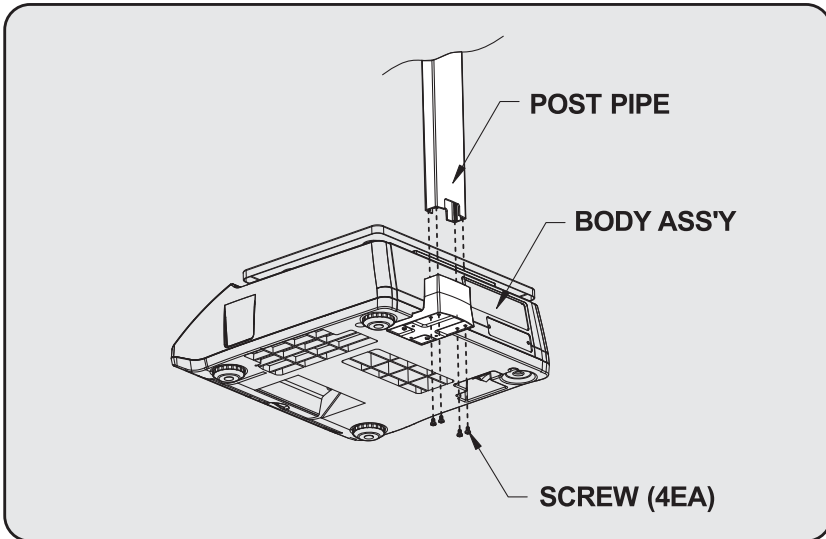

DISPLAY

- Front(Clerk-side display)& Pole Display ex) 15kg Version

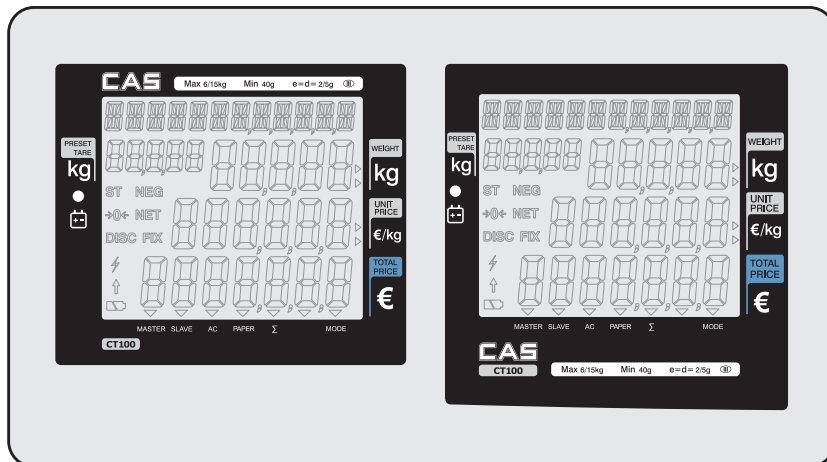

KEYBOARD

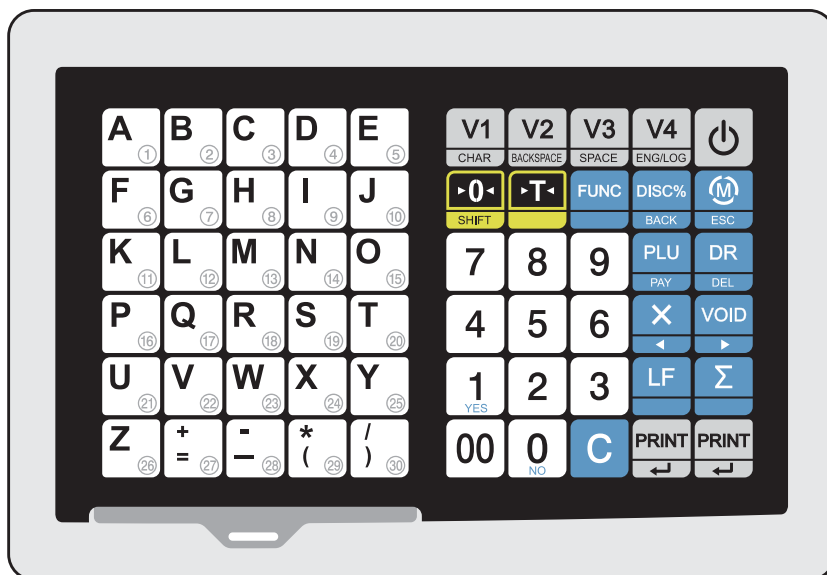

Table 1 : Symbols on Display

































SYMBOLS	DESCRIPTION
MASTER (▼)	Master mode
SLAVE (▼)	Slave mode
AC (▼)	AC power mode
PAPER (▼)	When blinks there is some problem with paper roll in the printer.
∑ (▼)	In the subtotal mode
↑	SHIFT key pressed
→0←	To adjust the weight to zero.
ST	Stable
NET	Tare on
MODE (▼)	Program mode
	Low battery warning when it is below 11.6 voltage
DISC	Discount price
NEG	Negative transaction
FIX	Fixed price
	Communication working

Table 2 : Key Functions

KEYS	FUNCTIONS	
	SALES MODE	PROGRAM MODE
	To input all numerical data	
	To input double zero	
	To clear all of numbers input on the display	
	To select clerk 1~4	
	To select clerk 5~8 (option)	
	To set zero	
	To set or clear tare value	
	To go to program mode	
	To call up a PLU with numeric key	
	To input non-weighed item	
	SHIFT : To select alternate key functions	
	To turn on or off the power / backlight	
	To show subtotal / total / payment sum	
	<p>Direct PLU keys</p> <p>* PLUs # 1~30 may be used for both the direct and indirect PLUs. Most commonly used 30 items are recommended to be used for direct PLUs for users' convenience.</p>	
	To change key map	

KEYS	FUNCTIONS	
	SALES MODE	PROGRAM MODE
	To open cash drawer *The cash drawer is opened no matter how the "opening time" is set.	
	To feed the paper	
	To make discount	
	After pressing 	After pressing 
	* To finalize the payment in cash * To print receipt	To print current data
	PAY : To pay in cash	
	SHIFT + PAY : To pay in credit	
	To make discount for subtotal	
	◀ : Sales list -	To go to the previous menu
	▶ : Sales list +	To go to the next menu
	DEL : To delete a specific sale in sales list	
		BACK : To go back to the higher level of menu
		ENTER : To go into the lower level of menu
		Fast selection of PLU (-) in the PLU mode
		Fast selection of PLU (+) in the PLU mode

I. Sales Mode

Chapter 1. Basic Operation

- a. Turning the scale or backlight on / off
- b. Feeding the paper
- c. Opening cash drawer
- d. Self-test on printing
- e. Zero function
- f. Tare function

Chapter 2. Sales for weighed item

- a. Sales with free price (hand pricing)
- b. PLU sales

Chapter 3. Sales for non-weighed item

- a. Sales with free price (hand pricing)
- b. PLU sales

Chapter 4. Clerk Operation

- a. CLERK MODE 0 (All clerk operation)
- b. CLERK MODE 1 (Only one clerk operation)
- c. CLERK MODE 2 (Supermarket mode)
- d. CLERK MODE 3 (Label-1 mode)
- e. CLERK MODE 4 (Label-2 mode)

Chapter 5. Discount & Payment

- a. Discount for a single transaction
- b. Discount for subtotal
- c. Payment
- d. Duplicate receipt



Chapter 6. Sales Transaction Simulation

- * Sales with free price
- * Void
- * Programmed discount
- * PLU sales
- * Non-weighed sales
- * Subtotal
- * Discount for subtotal
- * Sales list viewing
- * Deleting a specific sale transaction
- * Payment in credit
- * Payment in cash

Chapter 1. Basic Operation



This chapter explains how to turn the scale or backlight on/off, feed the paper, open cash drawer, and do self-test on printer.

a. Turning the scale or backlight on/off

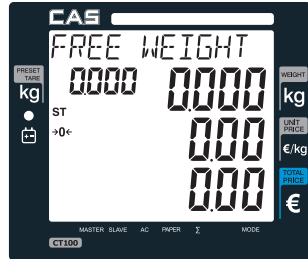
- ① Press  when the scale is turned off, then it starts counting 0~9. And press  again for a second to turn on backlight of scale.



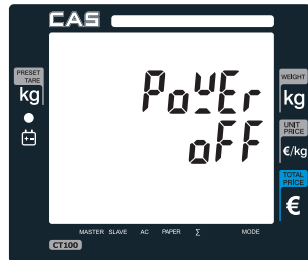

- Only when user is in battery use the backlight lasts 1 minute and automatically is turned off. Then, if the scale senses more than minimum weight the backlight is automatically turned on. Minimum weight : refer to **SPECIFICATION** Table on page 113.

- ② Press  for a second to turn backlight off. And press  and hold it for more than a second to turn the scale off.



b. Feeding the paper

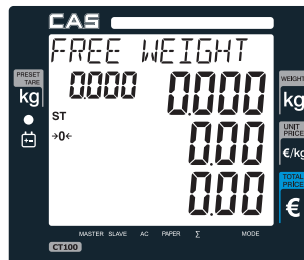

- Feeding the paper is to make sure that printer paper is properly set and operated.

- ① Press  when user needs to feed the paper. Paper will feed for as long as key is pressed. 
▼ (Shift) mark will be shown on the bottom of display.





c. Opening cash drawer

- This operation is to use the scale with cash drawer. The cash drawer is opened when the scale is connected to both AC power and 12 V battery
- Cash drawer will be opened whenever printing a receipt.
- Please set "Cash Drawer Open Time" to "1" if user doesn't want printing each time and use "DR" key. Refer to page 76 "f. Setting Pulse length to open cash drawer".

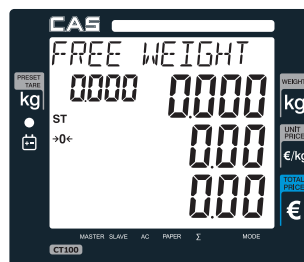
- ① Press  to open cash drawer in time set.
▼ (Shift) mark will be disappeared after pressing  key.



d. Self-test on printing

- ① Press  while counting 0~9 after turning on the scale by pressing . Then, it automatically prints out the test report. Please refer to the sample report on page 104.

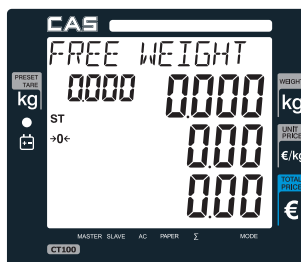

- The printing self-test function may be also executed on **test mode** in "**II. Programming mode**".

e. Zero function

- The scale is not in initial zero point when there is(are) any item(s) on the platter user may need to set zero using "zero" key.

- ① The scale is not in initial zero point.

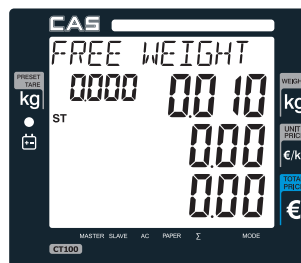
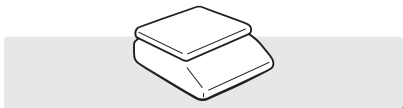

- ② Set zero point. User can set zero only within $\pm 2\%$ of capacity. For example, the 6kg CT100 model is $\pm 120\text{g}$.

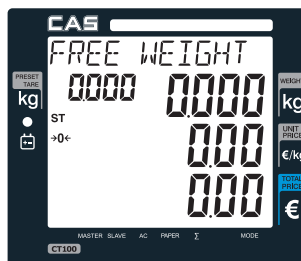

f. Tare function

■ One Time Tare

This function is to subtract the weight of actual tare.

- ① Place a tare on the platter. For example, 10g.

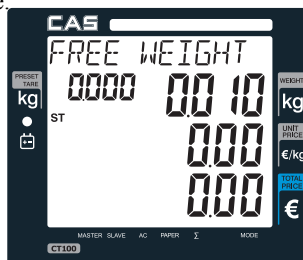
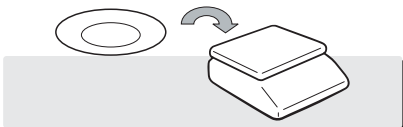

- ② Subtract the tare weight. After setting the tare user may place item on the platter, and the scale reads only the weight of item.

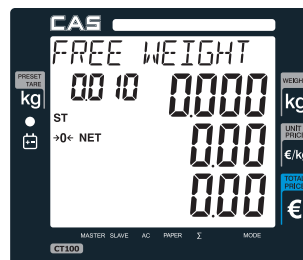

- ③ Remove tare from the platter if user does not need tare function. At this time the weight shows negative value of tare.

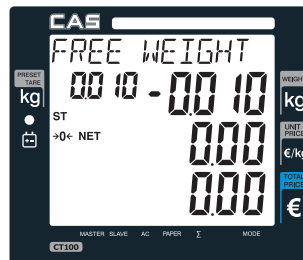
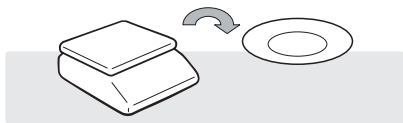

- ④ To clear up the tare value, and go back to set zero point, press the Tare key again.

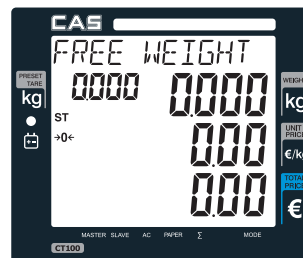

■ Successive Tare

This function is to subtract two successive tares.

The successive tare can be set in the calibration mode. Please contact your dealer if you want to use "Successive Tare".

- ① Place a tare on the platter. For example, 10 g.

Press the  key.

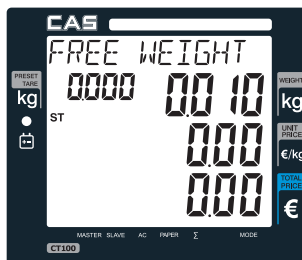
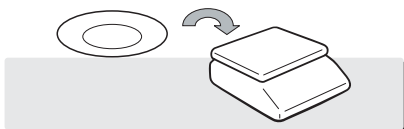

- ② The scale will subtract the tare weight.

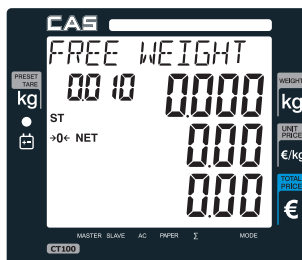

- ③ Place another tare on the platter.

For example, 20g.

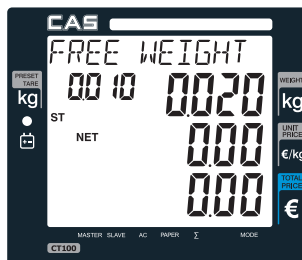
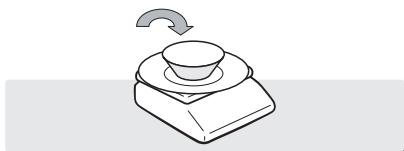

- ④ The scale will add up the weight of tares. After setting the successive tares user may place item on the platter, and the scale reads only the weight of item.

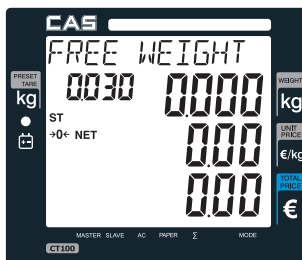

- ⑤ Remove all weights from platter if user does not need tare function. At this time the weight shows negative value of tare.

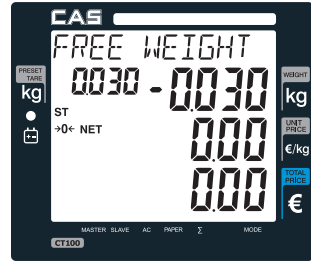
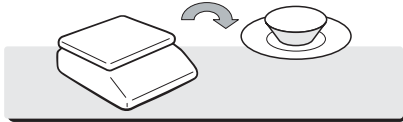

- ⑥ To clear up the tare value, and go back to set zero point, press the  key again.

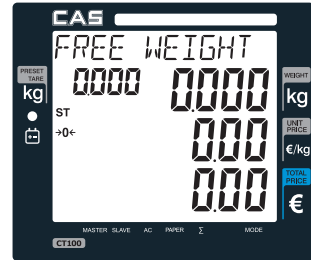

Next two chapters, **chapter 2 & 3**, explain how to make sales transactions for weighed item and for non-weighed item respectively. User may use or not use PLU (Price Look-Up), which can be pre-programmed into the scales. Let's look at how to operate the sales function of CAS CT100.

Chapter 2. Sales for weighed item

a. Sales with free price (hand pricing)

- Put appropriate item of, for example, 2kg on the platter and press numeric keys for its unit price in weighing mode.

* All of sales transactions with free price are stored and accumulated on "PLU 0" for report.

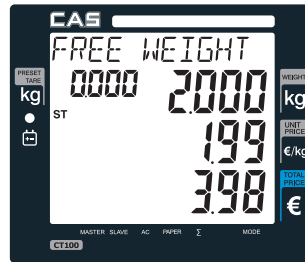
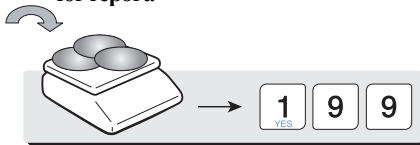

b. PLU Sales

PLU means Price Look-Up, which is pre-programmed into the scale for commonly used unit price and item. It may store such information as unit price, item code, department, item name, tax rate group, weighed or non-weighed, fixed or non-fixed item, and printing or non-printing barcode for a PLU.

CAS CT100 can store up to **1,000 PLUs** in its memory. Let's look at how to make a sales transaction using a PLU.

- Put appropriate item on the platter. And press either PLU number and  (or direct PLU key between 1~30 which are preset in the programming mode). For example, let's put in "PLU 1(non-fixed PLU)", which unit price is 2.99.

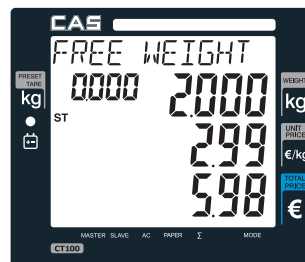
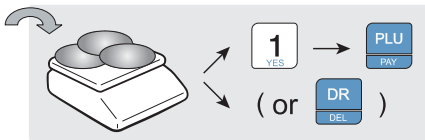

- * Direct PLU s: user may save one touch direct PLUs for most commonly-used 30 items.
- * If user saves indirect PLUs of #1~30 he/she does not need to save direct PLUs of # 1~30 because the indirect PLUs of #1~30 are automatically saved in the direct PLU keys of #1~30. Most commonly used 30 items are recommended to be saved in the direct PLU keys for users' convenience.

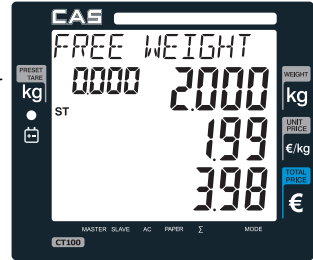

* If current PLU, 1 has **fixed price** attribute, which is set in the program mode user cannot change the unit price for PLU called up. However, if current PLU has non-fixed price attribute user may change (override) the unit price as his/her sales transaction requires.

- ① In case of non-fixed priced PLU user may put in (override) new price for current PLU at sales condition, for example, "last minute sales" or "10 minutes sales" etc. Lets try last minute sales of PLU 1; 1 kg for 1.99.





Chapter 3. Sales for non-weighed item

a. Sales with free price(hand pricing)

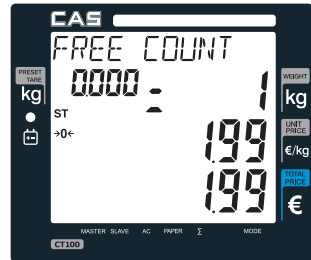
- ① Simply input item's unit price and press  key. Pressing  displays initial "1".



- ② For sales of only 1 item just press  because zero the quantity is already set to initial "1". Then, press  to select the clerk 1.

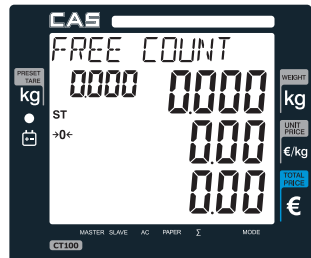

③ For more than single item sales,

Simply input item's unit price and press  and quantity. Then display will show total price.

* User may make sales up to 1,999 items per transaction.

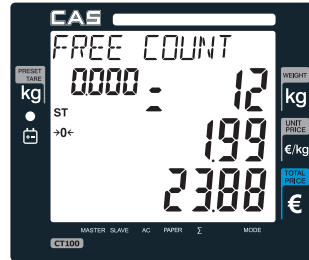

④ Press  to clear previous transaction and go back to initial weighing mode.

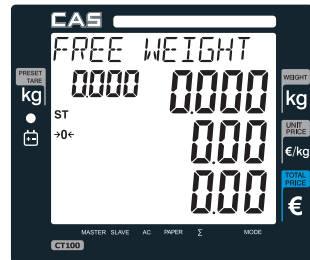



b. PLU Sales

- Please make sure current PLU is set with *non-fixed price* in the PLU program mode. Otherwise, user cannot change unit price for the PLU called up.
- User cannot change the unit price of "Fixed Price Item" after calling up the PLU.

① Press either PLU number and  (or appropriate direct PLU key between 1~30). For example, direct "PLU 8", which unit price is 3.99.

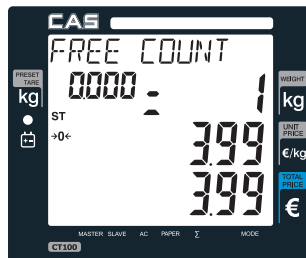
First press .



- ② Press  key to change unit price.

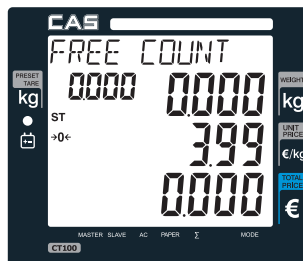

- ③ Input new price, 3.00. Then, press  and the number of non-weighed item unit, for example, 5 units.

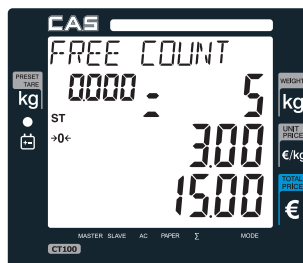

- ④ Press  to clear previous transaction and go back to initial weighing mode.

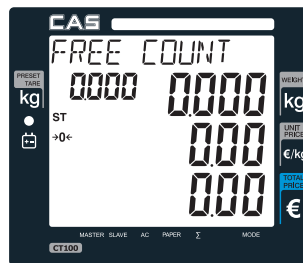

Chapter 4. Clerk Operation

There are three different type of clerk modes.

max number of sales per CLERK : 99

Table 3: Clerk Mode (refer to clerk mode setting on page 94)

Modes	DESCRIPTION	Receipt Printing
0	All clerks can use the scale for a series of sales activity.	It prints ticket (receipt) including each item and total information.
1	Only one clerk can use the scale for a series of sales activity. However, other clerk can use the scale for other series of sales activities in this mode.	It prints only part of ticket (receipt), which a transaction is made, and prints total amount after a series of transactions are completed.
2 (Supermarket mode)	Only one transaction per clerk at a moment.	It prints ticket (receipt) only for one transaction per clerk.
3(Label-1 Mode)	Only one transaction per clerk at a moment	It prints Label (receipt) only for one transaction per clerk.
4(Label-2 Mode)	Only one transaction per clerk at a moment	It prints Label (receipt) only for one transaction per clerk.

a. CLERK MODE 0 (All clerk operation)

- All clerks can use the scale for a series of sales activity.
- It prints ticket (receipt) including each item total information.

Assumption : (These are consecutive, separate, transactions.)

- 2kg of **Beef Sirloin** (PLU setting # 14, €3.99/kg, No weight; No) for clerk V1.
- 3kg of **Turkey** (PLU setting # 15, €4.99/kg, No weight; No) for clerk V2.
- 3kg of **Rib Eye** (PLU setting # 17, €5.99/kg, No weight; No) for clerk V3.
- 3 packs of **Potato** (PLU setting # 1, €1.99/pack, No weight; Yes) for clerk V1.Z
- e) All of above-mentioned PLUs should have other code number than "code 0".

① Call up PLU of Beef Sirloin, #14 for clerk V1.

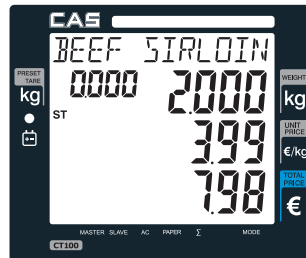
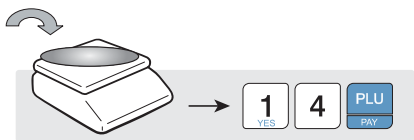

② Call up PLU of Beef Sirloin, #14 for clerk V1

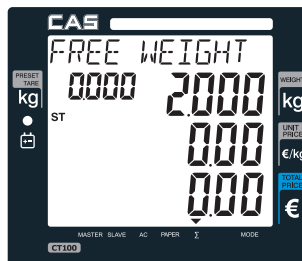

③ Select the clerk 1.

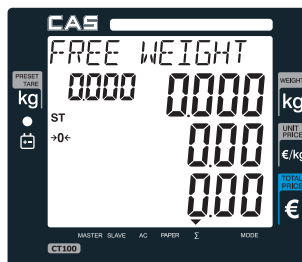
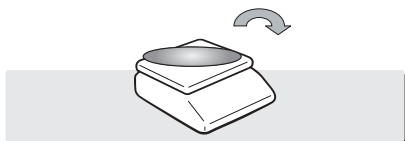

④ Remove Beef Sirloin from the platter.

⑤ Call up PLU of Turkey, #15 for clerk V2.

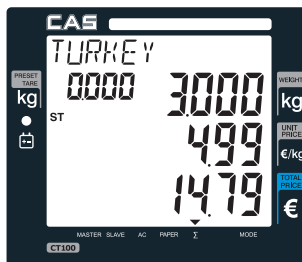
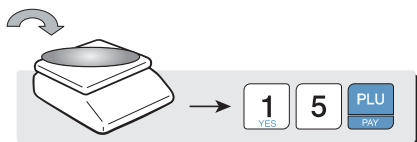

⑥ Select the clerk V2.

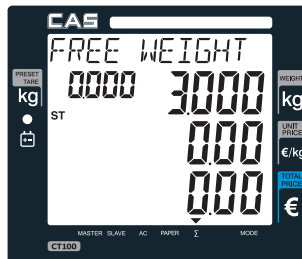

⑦ Remove Turkey from the platter.

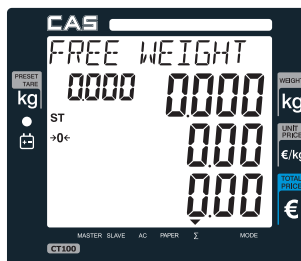
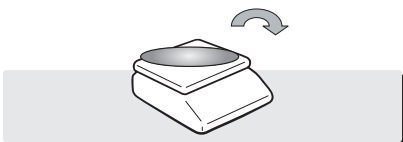

⑧ Call up PLU of Rib Eye, #17 for clerk V3.

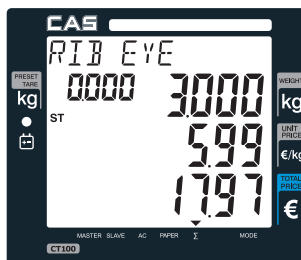
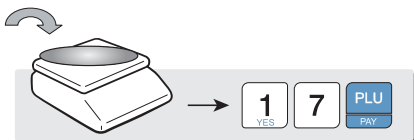

⑨ Select the clerk V3.

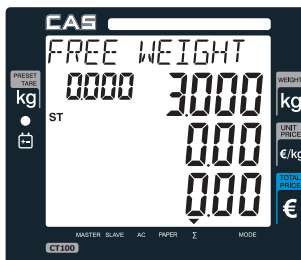

⑩ Remove Rib Eye from the platter.

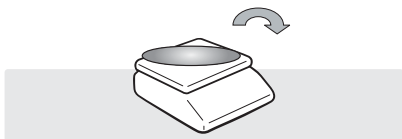

- ⑪ Call up PLU of Potato(No weight Item), #1 for clerk V1. Customer purchase 3 packs of Potato.

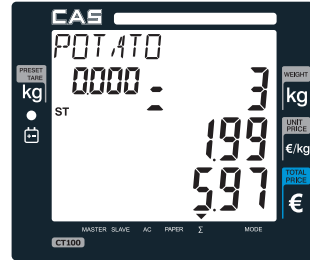
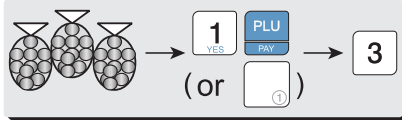

- ⑫ Select the clerk V1.

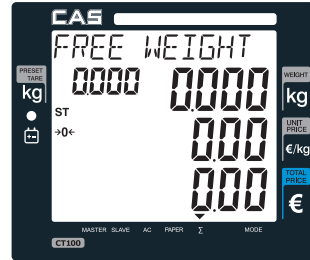

- ⑬ Subtotal Mode.
Get subtotal amount.

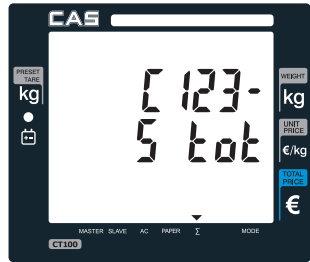

- ⑭ Select appropriate clerk (V1, V2, V3, V4)
Selecting V1 in the SUBTOTAL mode and pressing Σ key prints out a ticket (receipt) for Clerk1 transaction(s).

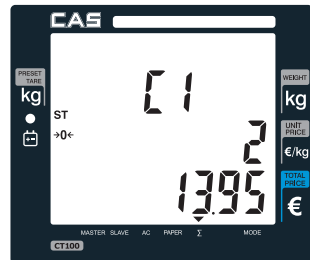

※ User may print out individual clerk's receipt by pressing individual clerk key (using Σ key) (using Σ key, Σ key, Σ key & Σ key) then Σ key.

- Receipt Samples (Euro Version)

Clerk 1' Receipt

CAS KOREA
82-31-828-1188

CLERK 1 Michle

Kg	€/Kg	€
Beef Sirloin		000288
2.00Kg	3.99	7.98 D
4482888833933		
Potato		000188
3x	1.98	5.97 A
4488883881982		
TOTAL €		13.95
CASH		13.95
TAX GROUP	TAX	TTL
A=18.88%	0.54	5.97
D=17.88%	1.16	7.98
NUMBER OF SALES		2
07/02/2004	11:17:55	000088
Thank You!		
Bye Bye		
4482883813951		

Clerk 2' Receipt

CAS KOREA
82-31-828-1188

CLERK 2 Brian

Kg	€/Kg	€
Turkey		0002201
3.00Kg	4.99	14.97 E
4483888884897		
TOTAL €		14.97
CASH		14.97
TAX GROUP	TAX	TTL
E=19.88%	2.39	14.97
NUMBER OF SALES		1
07/02/2004	11:18:04	000087
Thank You!		
Bye Bye		
4483888814872		

Clerk 3' Receipt

CAS KOREA
82-31-828-1188

CLERK 3 Suzi

Kg	€/Kg	€
Rib Eye		000203
3.00Kg	5.99	17.97 G
4483888885994		
TOTAL €		17.97
CASH		17.97
TAX GROUP	TAX	TTL
G=22.88%	3.24	17.97
NUMBER OF SALES		1
07/02/2004	11:18:12	000088
Thank You!		
Bye Bye		
4483888817973		

b. CLERK MODE 1 (Only one clerk operation)

- ① For example, put 2kg of item whose unit price is 3.99 and clerk V1 is making current transaction.

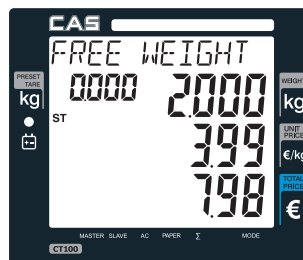
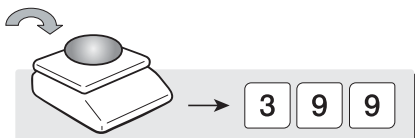

- ② Press Σ to select the clerk 1. It automatically prints out ticket (receipt) for current transaction.

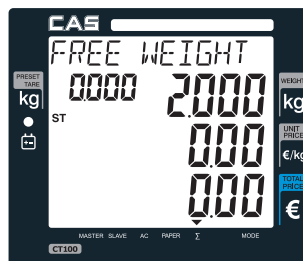

③ VOID

Press $\text{SHIFT} + 0$ and $\text{SHIFT} + X$ to void (delete) latest transaction. Clerk 1 to make sure the latest transaction is voided (deleted).

For Clerk Mode "0" user should press appropriate clerk deleted after pressing "Shift" + "X" key.

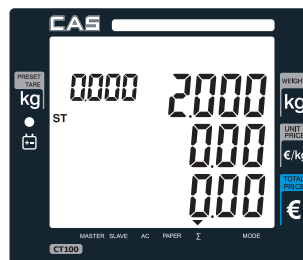

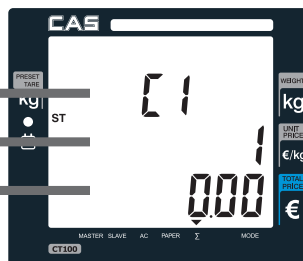
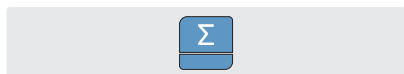

- ④ Press Σ to have subtotal amount and transaction after previous void transaction.

- Current clerk number in current transactions.
- The number of transactions.
- Total price through previous transactions.



⑤ Sales List

User may check through previous ①~④ transactions (lists) before printing receipt, using  or .

- Pressing  will delete current transaction made in the sales list mode.

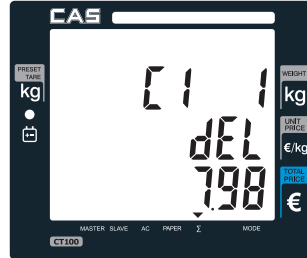
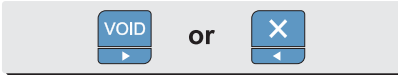

- ⑥ User may exit from current by using  once for current clerk's sales and twice for another transaction.

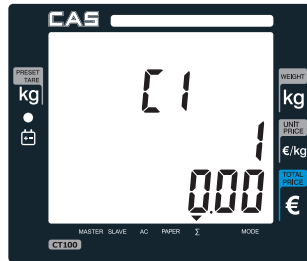

- ⑦ Press  to print the receipt for ①~⑥ steps, and the receipt looks like the following one.

A receipt printout from 'CAS KOREA' with various fields and labels pointing to them:

- Graphical Logo:** Points to the top image of a building.
- Header line:** Points to the 'CAS KOREA' text.
- Clerk 1:** Points to 'CLERK 1 82-31-828-1188'.
- Sales with Free Price:** Points to the 'FREE PRICE' section showing '2.880kg 3.99 7.98'.
- VOID transaction:** Points to the 'VOID' section showing '2.880kg 3.99 7.98'.
- PLU Code Number:** Points to the barcode and '4402900003063'.
- Receipt Number:** Points to 'TOTAL € 0.00'.
- Footer line:** Points to 'Thank You! Bye Bye'.

c. CLERK MODE 2 (Supermarket mode)

- *Only one transaction per clerk* at a moment.
- It prints ticket (receipt) only for one transaction per clerk.

Assumption :

- Please go to clerk mode and set clerk mode as "2 (supermarket mode)".
- 2kg of **Beef Sirloin** (PLU setting # 14, €3.99/kg, No weight; No) for clerk V1.
- All of above-mentioned PLUs should have other code number than "code 0".

① Call up PLU of Beef Sirloin, #14 for clerk V1.

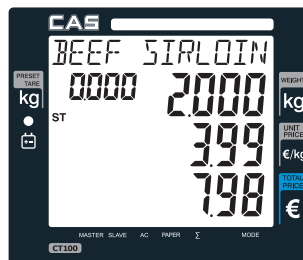
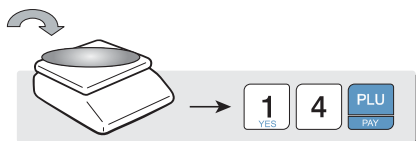

② Then, *it automatically prints out ticket* (receipt) for "a)" transaction when user selects the clerk.

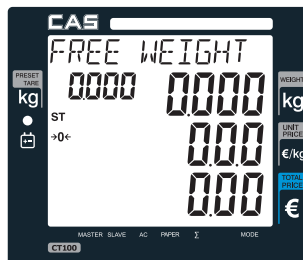

※ The scale prints out ticket (receipt) for each transaction in *the supermarket mode (set "2")* whenever each transaction is made by a clerk.

※ For further information please refer to "*chapter 11. Barcode Printing*" on page 85.

※ For further information please refer to "*chapter 11. Barcode Printing*" on page 85.

d. CLERK MODE 3 (Label-1 mode)

- **Only one transaction per clerk** at a moment.
- It prints Label format receipt only for one transaction per clerk.

Assumption :

- Please go to clerk mode and set clerk mode as "3 (Label-1 mode)".
- 2kg of **Beef Sirloin** (PLU setting # 14, €3.99/kg, No weight; No, Valid=30) for clerk V1.
- All of above-mentioned PLUs should have other code number than "code 0".

① Call up PLU of Beef Sirloin, #14 for clerk V1.

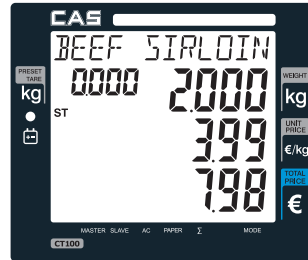
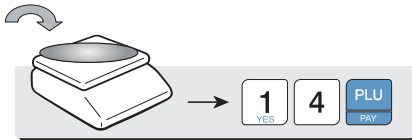

② Then, it **automatically prints out ticket** (Label format receipt) for "a" transaction when user selects the clerk.

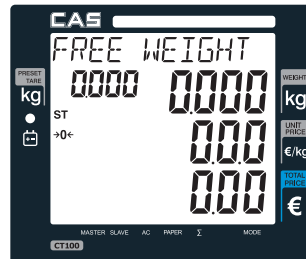

※ The scale prints out ticket (Label format receipt) for each transaction **in the Label-1 mode (set"3")** whenever each transaction is made by a clerk.



Receipt Number

Footer Line (2 Line)
(refer to Logo setting)



e. CLERK MODE 4 (Label-2 mode)

- **Only one transaction per clerk** at a moment.
- It prints Label format receipt only for one transaction per clerk.

Assumption :

- Please go to clerk mode and set clerk mode as "4 (Label-2 mode)".
- 2kg of **Beef Sirloin** (PLU setting # 14, €3.99/kg, No weight; No, Valid=30) for clerk V1.
- All of above-mentioned PLUs should have other code number than "code 0".

① Call up PLU of Beef Sirloin, #14 for clerk V1.

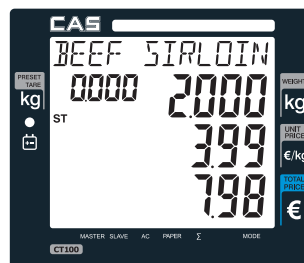
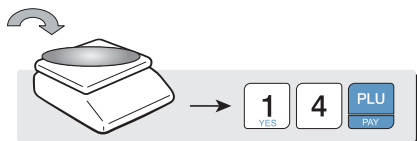

② Then, it **automatically prints out ticket** (Label format receipt) for "a)" transaction when user selects the clerk.

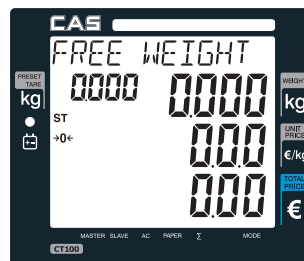

※ The scale prints out ticket (Label format receipt) for each transaction **in the Label-2 mode (set '4')** whenever each transaction is made by a clerk.

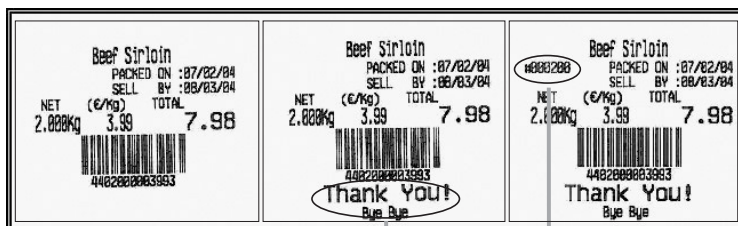

Footer Line (2 Line)
(refer to Logo setting)

PLU Code Number
(refer to Option PrCode)

Chapter 5. Discount & Payment

a. Discount for a single of transaction

■ Instant

Assumption :

- Instant discount rate: 10%
- Unit price of a commodity: €20

① A customer purchased €20.00 for a commodity.

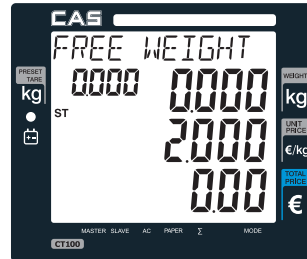

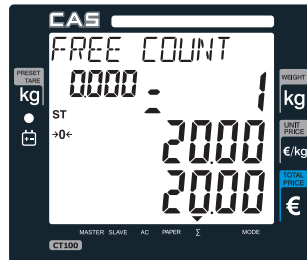

② Press **X** **V1** to make €20.00 valued sales transaction for clerk V1.

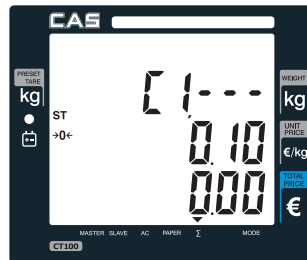

③ Press **1** **0** **DISC%** to provide 10% discount for current single transaction.



- ④ Press    to have the amount of Subtotal after instant 10% of discount for a single transaction.

*** CLERK"1"MODE :**

User doesn't need to select a "Clerk", .

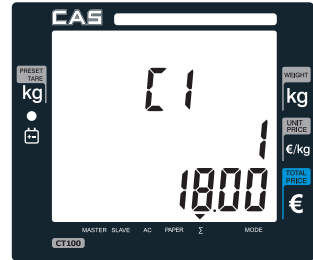

- Pressing  is to finalize the discount for a single transaction and print out the receipt.





- Programmed discount

Assumption :

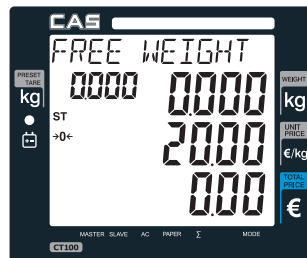

- Programmed discount rate: 5%
(Refer to "program mode" → "SET1" → "Pr-" for discount rate setting)
- Unit price of a commodity: €20

- ① A customer purchased €20.00 for a commodity.



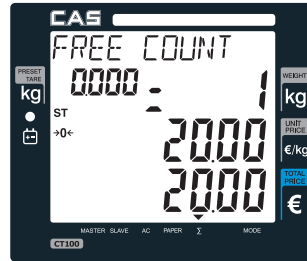

- ② Press   to make €20.00 sales transaction for clerk V1.

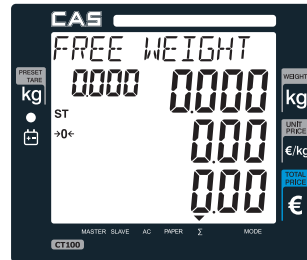

- ③ Press   to provide 5% programmed discount for current single transaction.



- ④ Press   to have the amount of subtotal after instant 5% of discount for a single transaction.

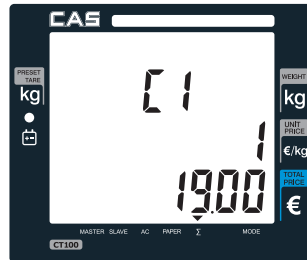

- Pressing  is to finalize the discount for a single transaction and print out the receipt.





b. Discount for subtotal

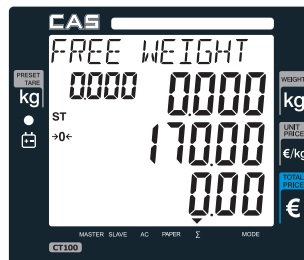

Once the user gets the total amount by pressing  he/she may apply some percentage of discount to the subtotal. Let's assume we apply a **6% discount** (refer to II. program mode, SET 1) on a purchase of €170 valued commodity, for example.

- ① A customer pays €170.00 for a commodity.

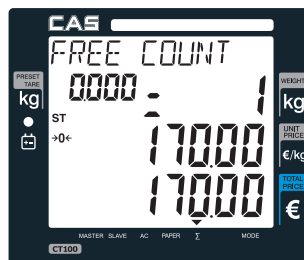

- ② Press   to make €170.00 sales transaction for clerk V1.



- ③ Press  and  to have the amount of subtotal which clerk V1 made.

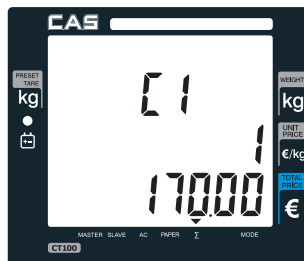

- ④ Press  to show the subtotal after programmed 6% discount.

※ You may apply "Instant discount" function to subtotal amount.

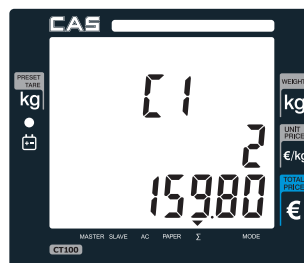
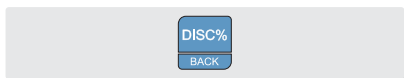

- Pressing  will to finalize the discount transaction and print out the receipt.





c. Payment

- Payment function works only in the *subtotal mode*.

Assumption : After clerk 1 has made three sales transactions the subtotal amount of €46.48 comes up. Customer wants to pay €20 in credit and rest in cash.

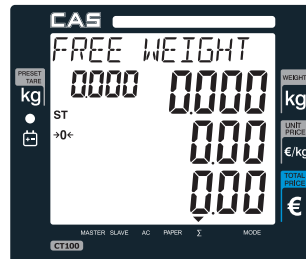
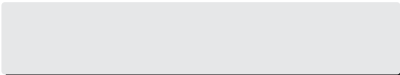
- ① ▼ indicates that current display is in subtotal mode as above assumption.



- ② Press  and  to have the amount of subtotal for clerk 1 as an example.

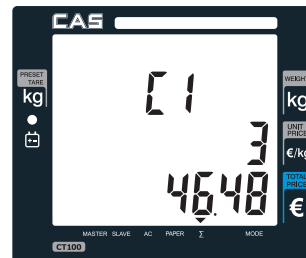

- ③ Press appropriate numeric keys to input the amount of payment *in credit*.

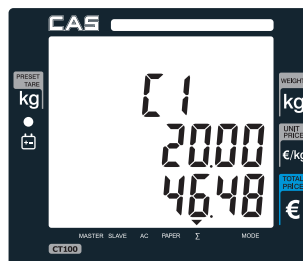

- ④ Press  and "pay" key to make payment *in credit*.

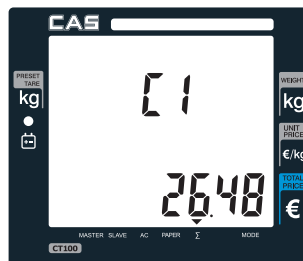

- ⑤ Press appropriate numeric keys to make rest of payment, €40.00 *in cash*.

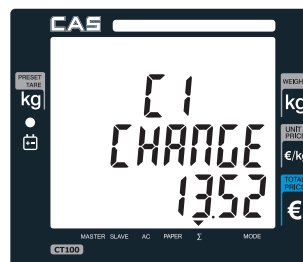



⑥ Then, the scale automatically prints out receipt.





- If user is using the scale with *cash drawer* connected *the cash drawer* is also automatically opened as the pulse length of cash drawer set when printing the receipt. **Default** for pulse length of cash drawer is **50 m/s** (50/1,000 second). Please refer to page 76 for further detail of "pulse length setting"

d. Duplicate receipt

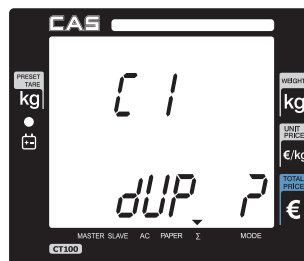
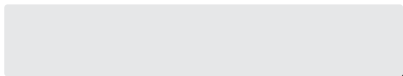

- If user sets duplicate receipt ("*dbL*") as "YES" in the **OPTION setting** (refer to page on 83) of program mode the scale asks "DUP?" whenever printing receipt by using  or PAY key. If user presses  it prints the additional copy of receipt, and if press "C" key it does not print copy of receipt.

- ① he scale asks user "dup?", when he/she has already printed out a receipt for current transaction.

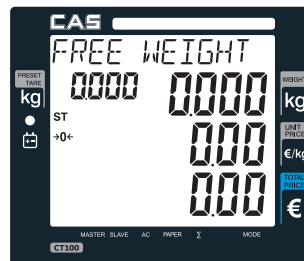
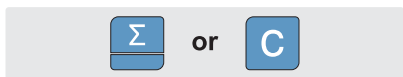

- ② Press either  to print an additional copy of receipt or  not to print the copy.



- Printing receipt works only in the subtotal mode.
- Usually, user can automatically have receipt by using  .
- However, if "**Obligatory Pay**" function **setting** (refer to page on 87) is already set in the **OPTION** setting the scale does not automatically print out the receipt by pressing  . In this case user must input the amount of payment more than current total amount and then he/she can make a payment in cash or credit.

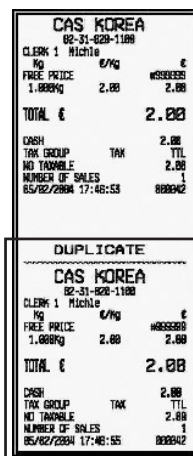

Chapter 6. Sales Transactions Simulation

Assumption :

- Clerk sales mode: "0"- *All clerks sales mode* (Clerk mode on page 92)
- Programmed discount: 5% (Discount percentage mode on page 69)
- Obligatory payment function: "0"-*disabled* (Obligatory payment setting on page 87)
- Duplicate receipt function: "0"-*disabled* (Duplicate receipt setting on page 83)
- Weight of commodity: 0.500 kg, and 1.000 kg

- ① Commodity (Kiwi) with free price, €1.00,
Weight=0.500 kg, clerk 1 sales.

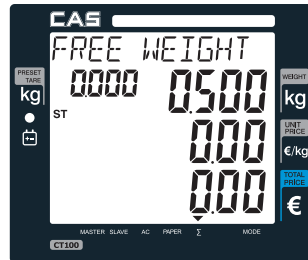

- ② Commodity (Melon) with free price, €2.00,
Weight=0.500 kg, clerk 1 sales.

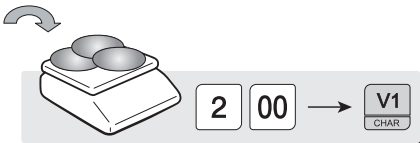

- ③ Void function

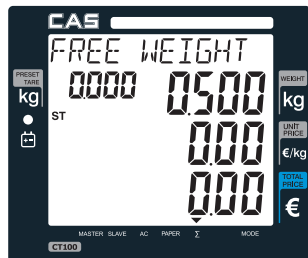

- ④ PLU 3 commodity (Tomato: €1.99/kg),
Weight=0.500 kg, clerk 1 sales.

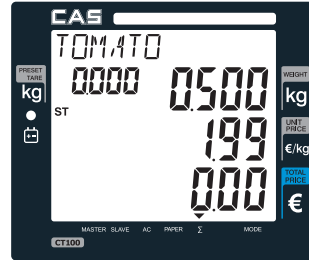
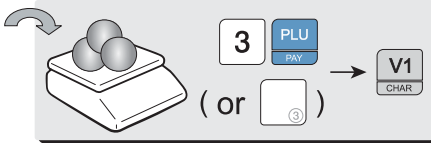

- ⑤ Programmed discount (5%) for PLU 3
commodity (Tomato), Weight=0.500kg,
clerk 1 sales.

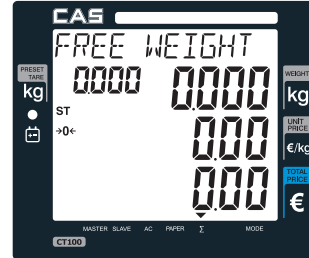
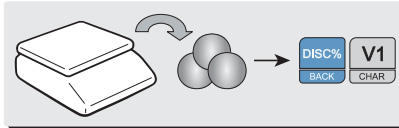

- ⑥ €5.00 of Non-weighed Free Price commodity
(Garlic bread) x3, clerk 1 sales.

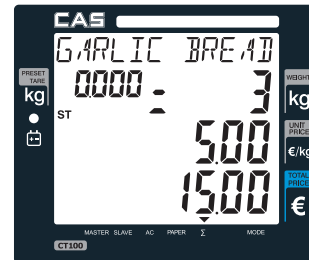

- ⑦ Subtotal, for example, €16.45. Total 4 transactions,
and clerk 1 sales activities are shown on the
display.

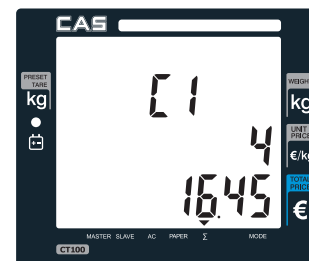

⑧ Discount 10% for subtotal, €16.45.

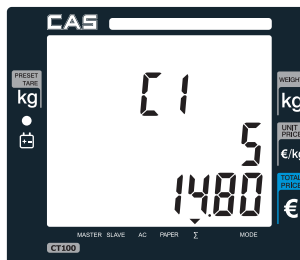

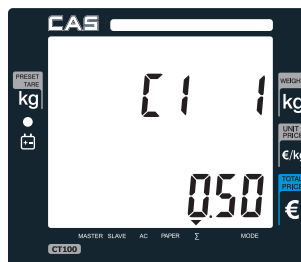

⑨ To review sales list press .

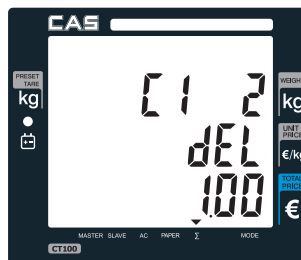

⑩ To review sales list press . "dEL" means VOID function has deleted the second transaction.



⑪ To review sales list press . "p 3" means that PLU 3 transaction has been completed. If user wants to exit from sales list press .

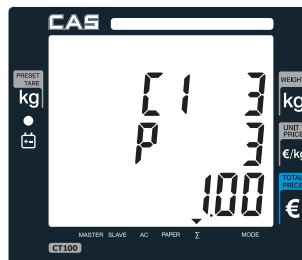

- ⑫ If user presses **C** to go back to sales mode the display is shown as right.

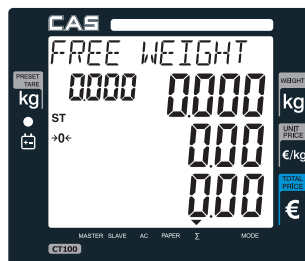

- ⑬ Two sales transactions for PLU 14 (€3.99/kg) and PLU 15 (€4.99/kg) with weight=0.500kg, clerk 1 sales activities.

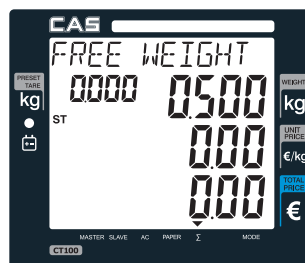
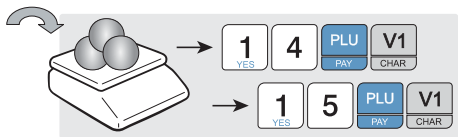

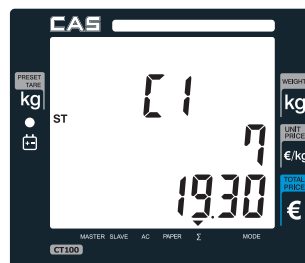

- ⑭ Subtotal mode. Subtotal is €19.30, for example.





Deleting sales transaction in subtotal

- To delete a specific sales transaction user should go to the sales transaction on the sales list by using **VOID** **X** key.
- Then, press **X** to delete it.
- If any discount transaction is done for subtotal the sales included in the subtotal can not be deleted.
- User can not execute **Void function** of a sales transaction if any discount for the subtotal is already made.

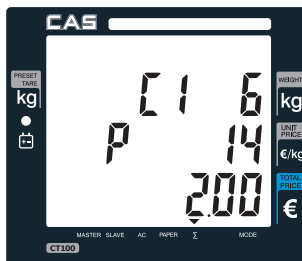
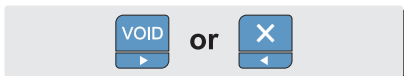
- 15 Go to the 6th sales transaction by using   to delete it.



- 16 Press  to delete it. User may exit from this mode by pressing .

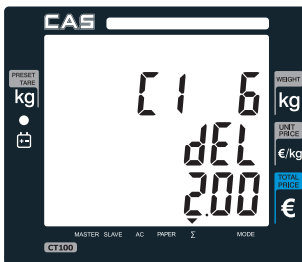

- 17 Payment of €10.00 *in credit* and rest *in cash* for total €17.30 for example. Input €10.00 of payment in credit.

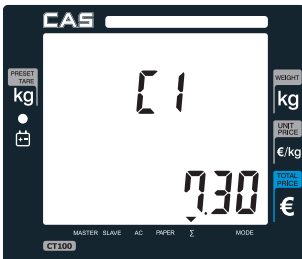

- 18 Input €20.00 to pay for remaining balance in cash.

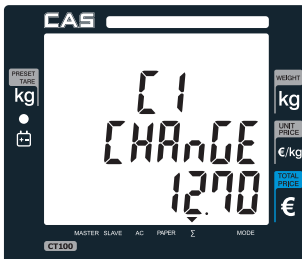

- The receipt will be automatically printed and the scale is ready to exit to sales mode.

Receipt Sample from Sales Simulation



CAS KOREA
82-31-820-1100

CLERK 1 Nichle

Kg	€/Kg	€
FREE PRICE		#999999
0.500Kg	1.00	0.50
FREE PRICE		#999999
0.500Kg	2.00	1.00
Tomato		#123402
0.500Kg	1.99	1.00 C
DISCOUNT	-5%	-0.05
FREE PRICE NOWEIGHT		#999998
3x	5.00	15.00
SUBTOTAL		16.45
DISCOUNT	-10%	-1.85
Beef Sirloin		#000200
0.500Kg	3.99	2.00 D
Turkey		#000201
0.500Kg	4.99	2.50 E
VOID		
FREE PRICE		#999999
0.500Kg	2.00	-1.00
VOID		
Beef Sirloin		#000200
0.500Kg	3.99	-2.00 D
TOTAL €		17.30
CASH		20.00
CREDIT		10.00
CHANGE		12.70
TAX GROUP	TAX	TTL
NO TAXABLE		13.95
C=15.00%	0.11	0.85
E=19.00%	0.40	2.50
NUMBER OF SALES		4
07/02/2004	11:40:27	000027

Thank You!
Bye Bye



4401503017306

II. Program Mode

Chapter 7. PLU Programming

- a. Validity
 - Price
 - Code
 - Department
 - Name
- b. Tax, Non Weighed, fixed PLU price & barcode printing
- c. One touch PLU data Erasing

Chapter 8. Report

- a. PLU data list
- b. PLU report
- c. Clerk report
- d. Department report
- e. Tax report and hourly sales report
- f. Closing report

Chapter 9. SET 1 (Discount, Barcode formatting & HW setting)

- a. Baud rate (bps)
- b. Auto power-off
- c. Discount rate(%)
- d. Barcode format setting for a single transactions
- e. Barcode format setting for total
- f. Setting pulse to open cash drawer
- g. Printing darkness setting
- h. Currency symbol or name

Chapter 10. SET 2 (Date, Time & Default setting)

- a. Date & Time
- b. One touch PLU data erasing & default setting

Chapter 11. OPTIONS (Receipt Formatting)

- a. Duplicate receipt
- b. Image (graphic logo)
- c. Printing barcode for a single transaction
- d. Printing barcode for total transaction
- e. Obligatory payment
- f. Discount
- g. Printing PLU code
- h. Printing all reports
- i. Printing Tax
- j. Use back light
- k. saving PLU

Chapter 12. Clerk

- a. Clerk mode
- b. Clerk name input : 1~4

Chapter 13. Logo











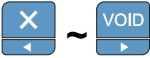

- a. Header & Footer setting
- Chapter 14. Tax rate group
Chapter 15. Test
ADC.
SPAN
Display
Keyboard
RAM
Printer
Battery voltage

Chapter 14. Tax rate group

Chapter 15. Test

- ※ ADC.
- ※ SPAN
- ※ Display
- ※ Keyboard
- ※ RAM
- ※ Printer
- ※ Battery voltage

Table 4 : Most commonly used keys in program mode

KEYS	FUNCTIONS
	PROGRAM MODE
	To get into program mode User can not get into program mode when Σ (\blacktriangledown) is on, that is, previous transaction(s) is not completed.
 ~ 	\blacktriangleleft ~ \blacktriangleright : To choose menu To move to previous or next character
	BACK : To go to the higher level of menu
	ENTER : To go to the lower level of menu To save number To get into edit mode
 ~ 	To input number To input number from an ASCII code
	To clear all text
	To delete characters like backspace key
	To input and save character in accordance to ASCII code
	To disable
	To enable
	ENTER : To save
	To clear

Chapter 7. PLU Programming



This chapter explains how to input all PLU-related data into the scale. User can store such information as price, code, group, name, tax rate group, weighed or non-weighed, fixed or not-fixed unit price, barcode printing etc. Lets look at how to input price information on the scale.

* PLU MEMORY CAPACITY : 1,000 Indirect PLUs
 30 Direct PLUs
 2 Special PLUs

Table 5 : PLU programming

PLU Programming	Minimum	Maximum	Remark
Validity Date	Remark	999	CLERK MODE 3, 4 "Label mode" only
Digits for Price	0 ~ 9999.99		
PLU Code	0(disabled)	999999	
group number	0	39	
PLU Name (character)	0	30	Iran Version Max = 24
Tax group	A ~ H		
Weighed or non-weighed item	Yes or No		
Fixed or non-fixed item	Yes or No		
Barcode printing or not	Yes or No		

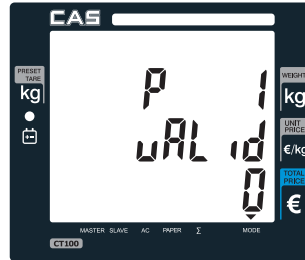

a. Validity, Price, Code, Department, and Name

- ① Press  key to get into PLU programming mode from main menu, and then press  key.



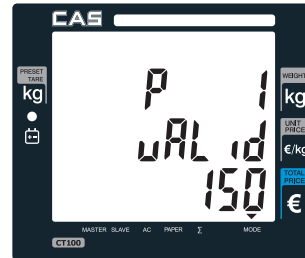

- ② To input PLU's validity press numeric keys you wish. For example, if you input 150 for PLU 1 press 1, 5, and 0 and press  to store.



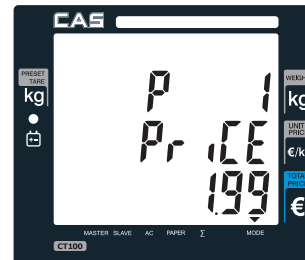

- ③ Press  to go to input unit price. To input PLU's unit price press numeric keys you wish. For example, if you input €1.99 for PLU 1 press 1, 9, and 9 and  to store.



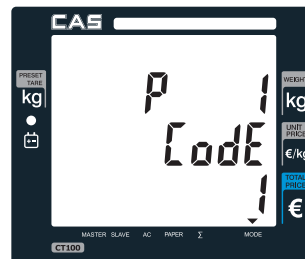

- ④ Press  to go to input code, and you can input any number of 0~999, 999. Then, press . For example, input 1 for this PLU.



- If user inputs "0" in the code for a specific PLU the PLU is disabled.

- ⑤ Press  to go to input group number, and you can input any number of 0~39, then, press  .
For example, input "1" for the group number.



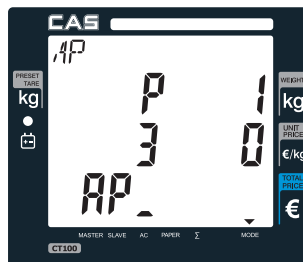
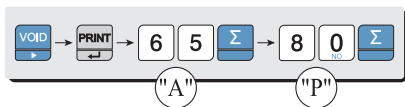

- ⑥ Press  to go to input PLU name,  . You can input up to 30 characters in accordance to Table 8: code on page 105. Then, press  to save the name. For example, input "APPLE" for PLU 1. Press numerical keys as followed.

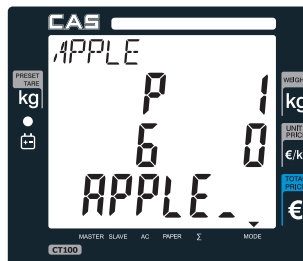
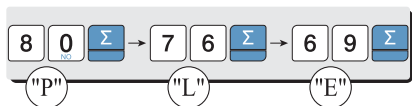

- ⑦ Press numerical keys as followed.



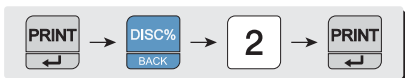

- ⑧ Press  to save the name input. If user wants to continue to input other PLU name he/she needs to exit to PLU mode by pressing  and appropriate numeric keys.





* If Maximum number of PLU is up to 1,799.

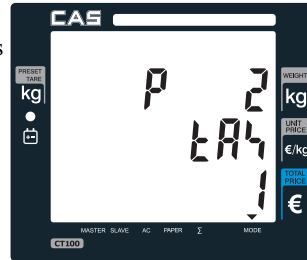

b. Tax, Non-weighed, fixed PLU price & barcode printing

- ⑨ Press  to go to tax group setting mode, and you can input any one of tax rate groups, A~H, then press . For example, input tax group 1 for this PLU (please refer to tax rate setting on page 99).



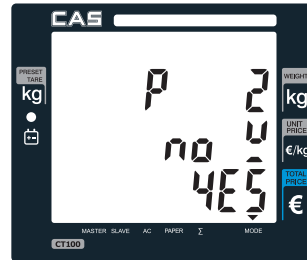

- ⑩ Press  to go to "non-weighed" setting mode. This setting is to select non-weighed or weighed commodity for current PLU selected. User can select YES or no by pressing "1" or "0" respectively. Then, press  to save it.

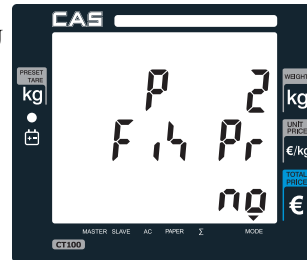

- ⑪ Press  to go to *fixed PLU price setting mode*. This setting is to select either fixed or non-fixed PLU price. If user select fixed PLU price he/she can not change unit price when called up the PLU. User can select YES or no by pressing "1" or "0" respectively. Then, press  to save it.



- ⑫ Press  to go to *barcode printing mode*. User can select YES or no by pressing "1" or "0" respectively. Then, press  to save it.

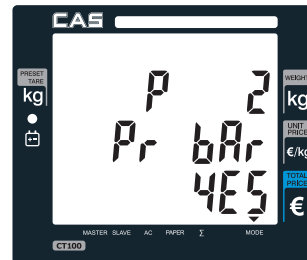

c. One touch PLU data Erasing



Please refer to [Chapter 10. SET 2. C.](#) for more detail.

Chapter 8. Report



This chapter explains how to print out all kind of reports in CT100.

CT100 provides such reports as PLU data list, PLU, clerk, department, tax, hourly, sales reports. All of report always includes two special PLUs, PLU 0 and 1,001 on top of report.

a. PLU data list

- ① Press  key to go to PLU programming mode from main menu, and then press  key.



- ② To print out list of all PLU data press  twice. Press  to stop printing of list if user wants.

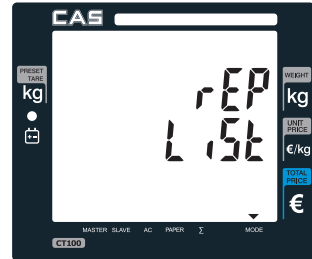

Sample Report

PLU LIST					
PLU	CODE	GR	TX	NFB	PRICE VALID
000099999	00	NNY		0.00	0
FREE PRICE					
100099998	00	YNY		0.00	0
FREE PRICE NOWEIGHT					
000100001	11	YNY		1.99	0
Potato					
000300003	00	NNY		1.99	0
Tomato					
001400014	11	NNY		3.99	0
Beef Sirloin					
001500015	02	NNY		4.99	0
Turkey					
001700017	00	NNY		5.99	0
Rib Eye					

Table 6 : "C" key operation while printing

Report	Does "C"(cancel) key work while printing report?	
	YES	NO
PLU data list	X	
PLU	X	
Clerk		X
Department	X	
Tax		X
Hourly sales		X
Daily sales		X
Monthly sales		X
Closing		X

b. PLU report

- PLU report always includes two special PLUs, **PLU 0** and **PLU 1,001**.
- PLU 0 is the sum of *non-PLU transactions and weighed item sales*.
- PLU 1001 is the *sum of non-PLU and non-weighed item sales*.

- ③ Press  to go to PLU report mode. This mode shows only PLU items sold and two special PLU items sold on the report.

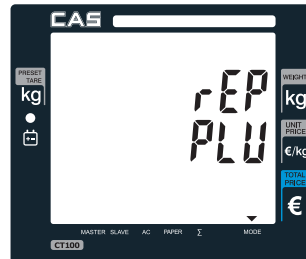

- ④ Users can select any between PLU 1 and 1,799 for setting report range. For example, select 1~20 for PLU report.



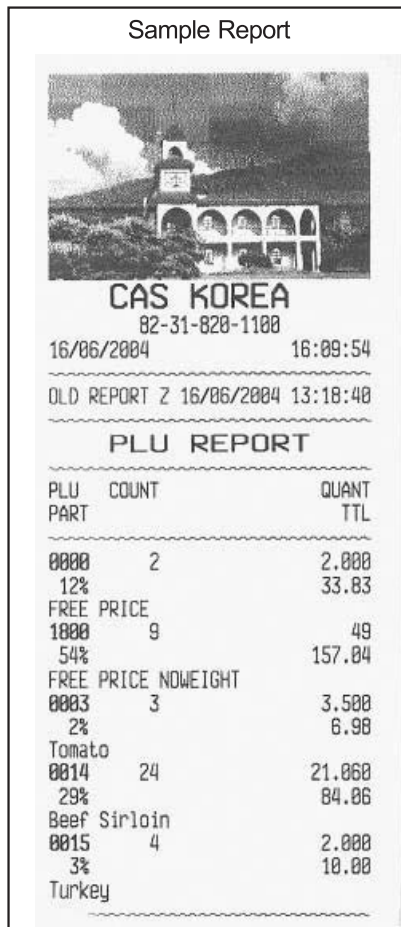
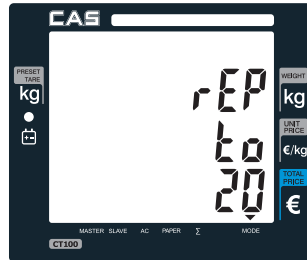

- ⑤ Automatically print out the PLU report ranging from 1 to 20, and two special PLUs.



c. Clerk report

- This reports *all sales-related activities for four clerks.*
- This report includes such information as the *number of clients* (customers), *clerks total sales amount, proportional percent of total sales amount, the amount and number of canceled transaction, the amount and number of discount, transactions and the amount of sales in cash and credit* respectively.

⑥ Press  to go to clerk report mode, and  press to print out the report.



Sample Report



CAS KOREA
82-31-828-1188

16/06/2004 16:25:25
OLD REPORT 2 16/06/2004 13:18:40

CLERKS REPORT

CLERK 1	
CLIENTS	11
TOTAL	152.57
COUNT	36
TOTAL PERCENT	52
TOTAL CANCEL	3.00
COUNT CANCEL	2
TOTAL DISCOUNT	1.78
COUNT DISCOUNT	2
TOTAL CASH	538.82
TOTAL CREDIT	18.00
CLERK 2	
CLIENTS	7
TOTAL	139.63
COUNT	7
TOTAL PERCENT	47
TOTAL CANCEL	0.00
COUNT CANCEL	0
TOTAL DISCOUNT	0.00
COUNT DISCOUNT	0
TOTAL CASH	258.28
TOTAL CREDIT	50.00
CLERK 3	
CLIENTS	1
TOTAL	1.99
COUNT	1
TOTAL PERCENT	1
TOTAL CANCEL	0.00
COUNT CANCEL	0
TOTAL DISCOUNT	0.00
COUNT DISCOUNT	0
TOTAL CASH	109.89
TOTAL CREDIT	0.00
CLERK 4	
CLIENTS	1
TOTAL	1.99
COUNT	1
TOTAL PERCENT	1
TOTAL CANCEL	0.00
COUNT CANCEL	0
TOTAL DISCOUNT	0.00
COUNT DISCOUNT	0
TOTAL CASH	109.89
TOTAL CREDIT	0.00

d. Group report

⑦ Go to the group report mode.



Sample Report



CAS KOREA
82-31-820-1100

16/06/2004 16:49:37
 OLD REPORT Z 16/06/2004 13:18:40

DEPART. REPORT

DEPART.	PART	TTL
A		
00	42%	226.69
B		
01	1%	3.00
D		
03	2%	8.97
F		
05	1%	4.00
H		
07	1%	7.00
J		
09	1%	8.00
L		
11	2%	9.00
N		
13	2%	10.00
P		
15	2%	11.00
R		
17	2%	12.00
T		
19	2%	13.00
U		
21	3%	14.00
X		
23	3%	15.00
Z		
25	21%	116.06
BBB		
27	4%	19.98
DDD		
29	1%	7.50
FFF		
31	3%	17.97
JJJ		
35	1%	6.00
LLL		
37	1%	7.00
DDD		
39	4%	24.00

e. Tax report, hourly, daily and monthly sales report

The same process as department report.

- Tax report: total tax amount and sales amount for each 8 tax groups.
- Hourly sales report: hourly sales total amount, count, and percent for a day.
- Daily sales report: daily sales total amount, count, and percent for a day.
- Monthly sales report: monthly sales total amount, count, and percent for a day.

Sample Report



CAS KOREA
82-31-620-1180

16/06/2004 17:01:07
OLD REPORT 2 16/06/2004 13:18:40

TAXES REPORT

TAX GROUP	TAX	TTL
NO TAXABLE		219.13
A=10.00%	12.37	136.83
B=20.00%	4.99	29.97
C= 1.20%	0.32	27.00
D=10.05%	4.04	53.00
E=20.00%	9.62	43.96
F=35.00%	8.94	34.50
G=40.00%	13.71	47.87
H=11.00%	1.60	17.00

Sample Report



CAS KOREA
82-31-620-1180

16/06/2004 17:01:19
OLD REPORT 2 16/06/2004 13:18:40

TIME REPORT

HOUR	COUNT	PERCENT	TTL
0	0	0%	0.00
1	0	0%	0.00
2	0	0%	0.00
3	0	0%	0.00
4	0	0%	0.00
5	0	0%	0.00
6	0	0%	0.00
7	0	0%	0.00
8	0	0%	0.00
9	0	0%	0.00
10	0	0%	0.00
11	0	0%	0.00
12	0	0%	0.00
13	32	18%	109.26
14	7	23%	141.64
15	0	0%	0.00
16	31	43%	259.71
17	9	16%	97.95
18	0	0%	0.00
19	0	0%	0.00
20	0	0%	0.00
21	0	0%	0.00
22	0	0%	0.00
23	0	0%	0.00

f. Closing report

This will set all of accumulated sums to zero and close all of daily sales activities by printing report.

- If user already sets "report all" function "YES" in OPTIONS setting of program mode the scale will automatically print all the reports included such as PLU data list, PLU report, clerk report, group report, tax report, hourly, daily and monthly sales report by executing.

Chapter 9. SET 1 (Discount, Barcode formatting & HW setting)

This chapter explains how to set BAUD rate, auto power-off, LAN number, discount rate, barcode format for a single or total, and pulse length for opening cash drawer. In addition to these, it also describes how to set printing darkness and input currency symbol or name.

Table 7 : SET 1

SET 1	Minimum	Maximum	Remark
BAUD 1 Rate (bps; bit per sec.) / BAUD 2 Rate	1200, 2400, 4800, 9600, 14400, 19200, 28800, 38400, 57600, 115200		User should turn off and on the scale after setting new "BaudRate".
Scale number (#)	1	99	
Discount Rate (%)	0	99	
Barcode Format			
Cash Drawer-Opening Pulse (ms.)	1	99	
Printing Darkness	1	5	Default : 3
Currency Symbol or Name (characters)	0	3	IRAN Version Max = 4
Font	1	3	1: 2: 3: Arial font

a. BAUD 1 rate (bps)

BAUD rate is the data-downloading or uploading speed between the scale and PC. User may set appropriate one of 10 speed options depending on his/her usage environment. This rate must match the baud rate of the com port (com1, com2, etc) in the PC.

① Press  and  to go to *SET 1 mode*.



b. BAUD 2 rate (bps)

- ① Press  to go to **BAUD rate setting mode**.
User may input any one of options 1200~115200
To meet best usage environment. Please refer to
"Table 7: SET 1" on page 68 for speed options.
For example, select 57600.

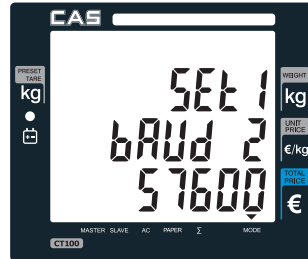

c. Discount rate(%)

- ① Press  to go to **Discount rate setting mode**.
This is to set programmed discount rate between
0~99%. For example, lets set 5 % of programmed
discount rate.

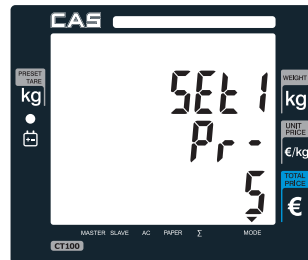

d. Barcode format setting for a single transactions

- ① Press  to go to *Barcode format setting for a single transaction mode.*

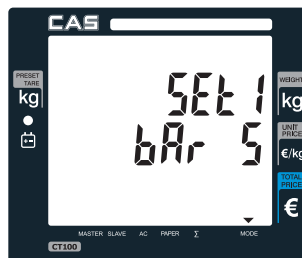

- ② Then, press  again to get into input barcode string, using code table on page 104. Now you can input appropriate barcode string.

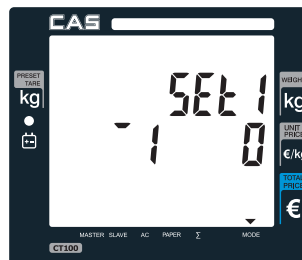

The barcodes are entered like string with specific format.

Barcode string: tMXNXNMXN...XN

- ▶ t : type of barcode (If the 'type of barcode' is not specified then EAN13 is printed.)
 - a : EAN13
 - b : UPCA
 - c : EAN8
 - d : CODE128 type

- ▶ X : The following information can be inserted at "X" location.
 - W : weight
 - U : unit price
 - P : total sum
 - N : code of PLU
 - B : number of receipt
 - D : department
 - C : vendor (1..4)
 - V : price control sum (using only EAN13 type)
("V" can be inserted only before "up to 5 digits for U (unit price)" or "up to 5 digits for P (total sum)" to make sure price-related information.)

- M : number of sales in receipt
- ▶ N : number of digit(s)
- ▶ M : constant digit(s)

The parameter X specifies what will be printed. You can choose between several parameters and can set how many digits will be printed.

The parameter N after parameter X is a obligatory! It give the number of digits which will be printed from value specified with parameter X.

The constant digits M is not obligatory, they can be insert anywhere in the string between group XN and will be print unconditionally.

The total number of digits in the barcode after interpretation must be stay exactly :

- **12 digits for EAN13 (1 digits by itself),**
- **11 digits for UPCA (1 digits by itself),**
- **7 digits for EAN8 (1 digits by itself),**
- **CODE128 have variable number of digits max 26.** (For this barcode are accepted only even number of digits. →Max Constant digits = 12digits)

If is set U, N or D type to total barcode then these values will be take from last sale!

If is set M for barcode for a single sale then value will be number of current sale.

☞ **Case 1 (EAN13 type) :**

Assumption:

- Weight -1.025
- Unit price - 2.28
- String- "**1W5VU5**" (total is 12 digits input)Then,

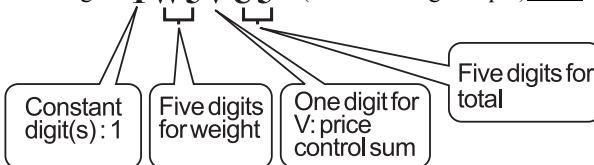

Barcode -> 1 01025 1 00228 (total is 12 digits input)



☞ **Case 2 (EAN13 type) :**

Assumption:

- Weight -1.550
- Department – 15
- Clerk - 1
- String- **a4W562D2C19** (total is 12 digits input)Then,

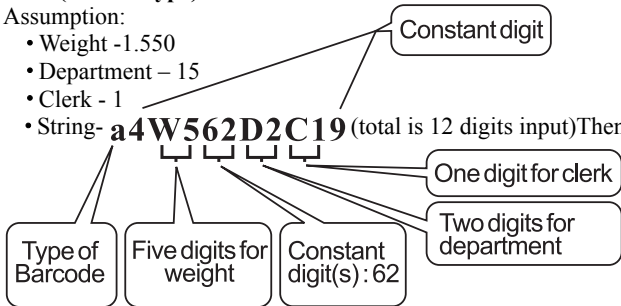

Barcode -> 4 01550 62 15 1 9 (total is 12 digits input)



The last digit is automatically set.

☞ **Case 3 (UPCA type) :**

Assumption:

- Weight -1.025
- Unit price - 2.28
- String- **"b1W5U5"** (total is 11 digits input)Then,

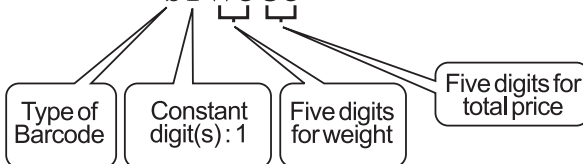

Barcode -> 1 01025 00228 (total is 11 digits input)



The last digit is automatically set.

☞ **Case 4 (EAN8 type) :**

Assumption:

- Number of receipt - 000579
- String- "**c2B6**" (total is 7 digits input) Then,

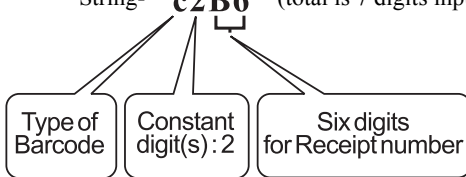

Barcode -> 2 000038 (total is 7 digits input)



The last digit is automatically set.

☞ **Case 5 (CODE128 type) :**

Assumption:

- CODE of PLU - 551256
- Weigh - 1.545
- Unit price - 20.00
- Total price - 30.90
- Clerk - 2
- String- "**d4N6W6U6P6C1**" (total is 26(max) digits input)

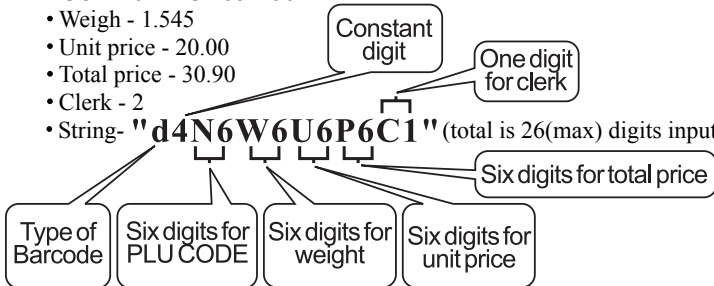

Barcode -> 4 551256001545 002000 003090 2 (total is 26 digits input)



Lets try to set barcode for above case 1. User should input codes- 49, 87,53, 86, 80, 53- for barcode string, **1W5VU5**.

- ③ Press **4** **9** and **Σ** to input "1", the first digit of string in *barcode for a single sale setting mode*.

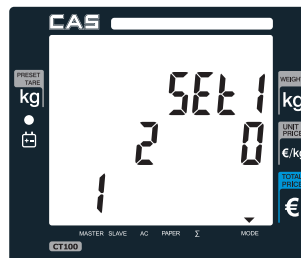

- ④ Press the following keys to continue to input barcode string.

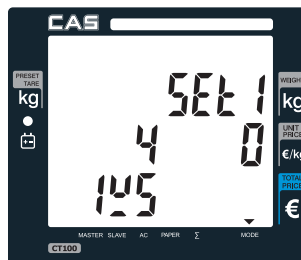
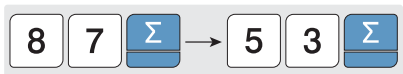

- ⑤ Press the following keys to continue to input barcode string.

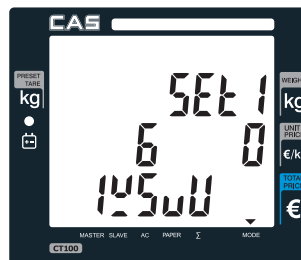
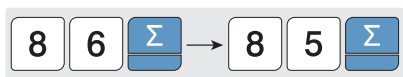

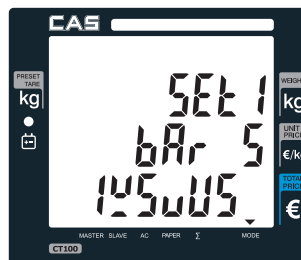
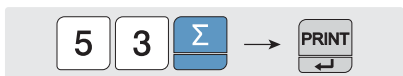

- ⑥ Press the following keys to continue to input barcode string.

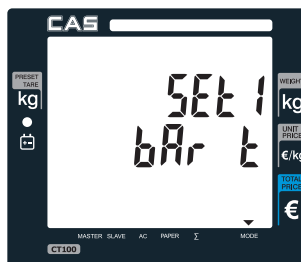

e. Barcode format setting for total

- ① Press  to go to *Barcode format setting for a total transaction mode.*



- ② Then, press  again to get into input barcode string using code table on page 105. Now you can to input appropriate barcode string.

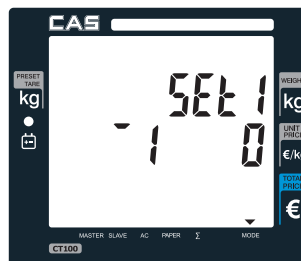

- Same method as *"d. barcode format setting for a single transaction."*

Example : Single Barcode Format = 1W5VU5 (EAN13)
 Total Barcode Format = 1W5VP5 (EAN13)

- Weigh - 1.545
- Unit price - 2.28
- Total price - 2.34



f. Setting pulse length to open cash drawer

- CT100 may be used with cash drawer 12 volts DC.
- Default for pulse length of cash drawer is 50 m/s (50/1000 second). However, user can select any of 1~99 ms, which is best fit for user's own cash drawer.

① Pulse length setting mode.

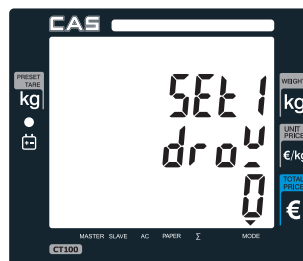

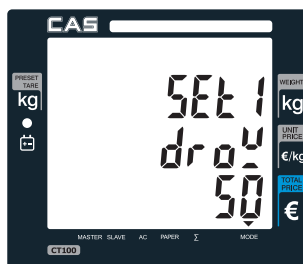

② Press appropriate numeric key to set pulse length of 1~99 (ms) and  to save it. For example, set 50 ms.

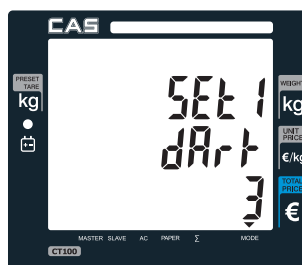

g. Printing darkness setting

① Printing darkness setting mode. User may set the darkness 1~5 and the default setting is 3.



- ② Press appropriate numeric key to set printing darkness of 1~5 and  to save it. For example, set 2. "5" is the most dark set.

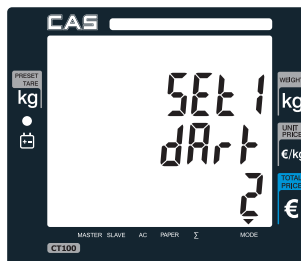

h. Currency symbol or name

- ① Currency symbol or name setting mode. User can input appropriate characters for currency, using code table on page 104. Maximum number of character is 3. Let's try to input "€" for Euro.

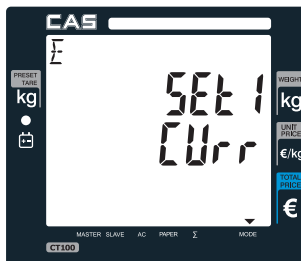

- ② Input "128" for € symbol.



- ③ Press  to save it.

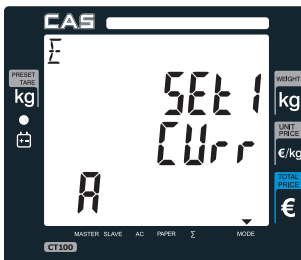



Chapter 10. SET 2 (Date, Time & Default setting)

This chapter explains how to set date and time, erase all of PLU data. In addition to these functions it also shows how to do one-touch default setting.

a. Date & time

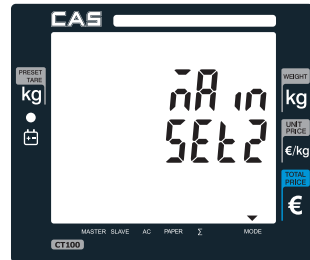
- ① Press  and  to go to *SET 2 mode*.



- ② Press  to go to *date setting mode*.



- ③ Press any numerical keys you wish to input. For example, let's input "24/06/04" as date, and press  to save date.

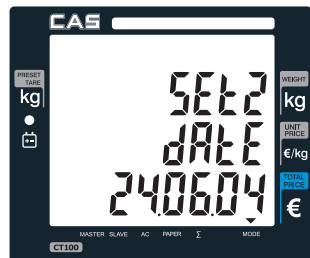

- ④ Press  to go to *Time Setting mode*.

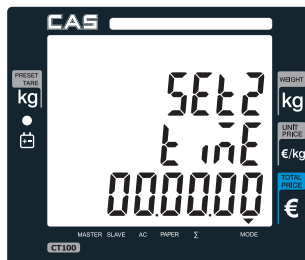



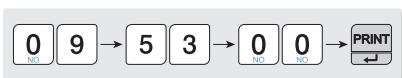

- ⑤ Press any numeric keys you wish to input. For example, lets input "09:53:00" as time, and press  to save time.

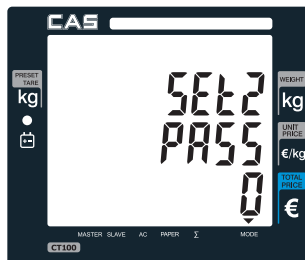



b. Password setting





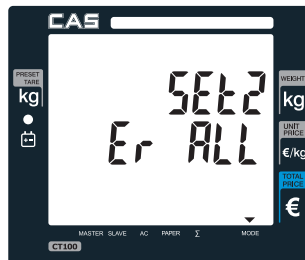
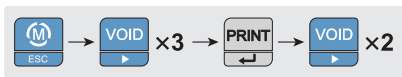

c. One touch PLU data erasing & default setting

- ① Using  and  go to *SET2 mode*. Then, press    to get *PLU Erasing mode*.

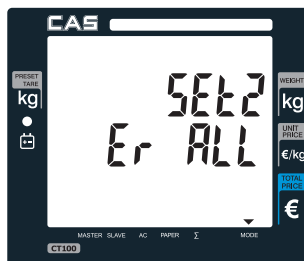

② Press  to erase all PLU data.



③ Press  to go to *default setting mode*.
Then, press  to set default.
(you can exit to normal weighing mode using ).

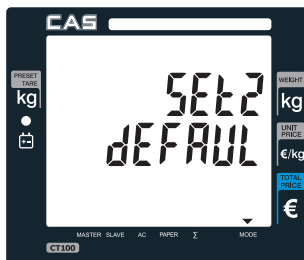

Default

<SET1>

- COM1 Baud Rate (bps) = 115200
- Discount Rate = 0%
- Printing Darkness = 3
- Font = 3
- COM2 Baud Rate (bps) = 115200
- Cash Drawer-Opening Pulse = 50ms
- Currency = €
- Scale = 1

<OPTION>



- Duplicate receipt = No
- Printing barcode for a single of transaction = Yes
- Printing barcode for total transaction = Yes
- Obligatory Payment = No
- PLU code printing = No
- Printing tax = Yes
- PLU SAVE = No
- Image (graphic logo) = No
- Discount = Yes
- Printing all reports = No
- Use Back Light = No

Chapter 11. OPTIONS (Receipt Formatting)





This chapter explains how to enable/disable back light and save PLU after transaction. duplicate receipt, printing barcode for a single transaction or total. It also explains how to enable/disable printing graphic logo on receipt, code of PLU and all of reports in the closing report. Furthermore, this chapter explains how to you to set obligatory payment function and discount function.

The option setting is *receipt-formatting functions* except obligatory payment and discount functions.



a. Duplicate receipt

- ① Using  key and  to get into *option setting mode* from main menu.



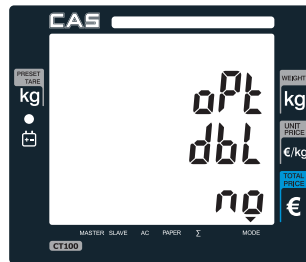



- ② Using  key and  go to *option setting mode* from main menu. And then press   to get into *duplicate ticket printing setting mode*.

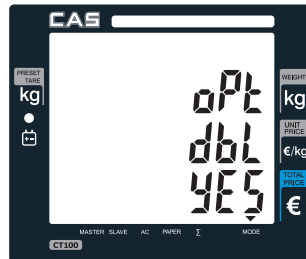



- ③ User may select YES or NO by pressing "1" or "0" respectively, and press  to save it. Use "C" key to change "1" or "0" input before saving by pressing .

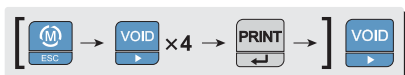

b. Image (graphic logo)

- ① (Using  key and  go to *option setting mode* from main menu. And then press )
 to get into *image setting mode*.





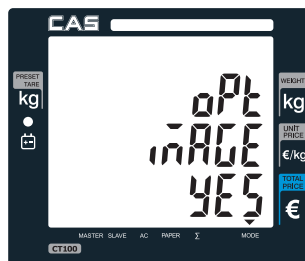

- ② User may select YES or NO by pressing "1" or "0" respectively, and press  to save it. Use "C" key to change "1" or "0" input before saving by pressing .





* *Image : Yes = printing graphic logo on receipt*

c. Printing barcode for a single of transaction

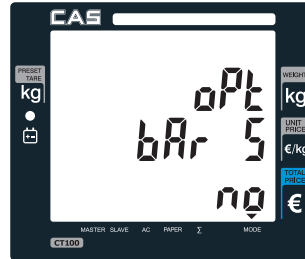



- ① (Using  key and  go to *option setting mode* from main menu. And then press )
 to get into *barcode printing for a single of transaction setting mode*.

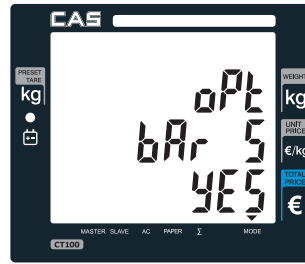



- ② User may select YES or NO by pressing "1" or "0" respectively, and press  to save it. Use "C" key to change "1" or "0" input before saving by pressing .

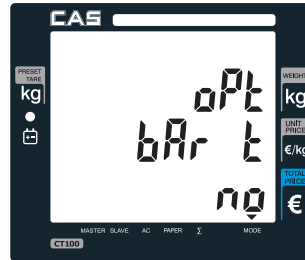

d. Printing barcode for total transaction

- ① (Using  key and  go to *option setting mode* from main menu. And then press )
 to get into *barcode printing for total transaction setting mode*.



- ② User may select YES or NO by pressing "1" or "0" respectively, and press  to save it. Use "C" key to change "1" or "0" input before saving by pressing .

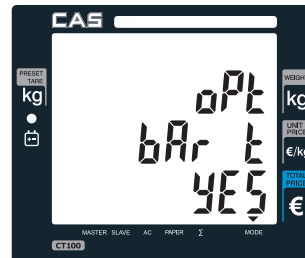

Barcode Prining Sample Receipts

Both of Single
& Total Barcode

Single Barcode Only

Total Barcode Only



CAS KOREA

82-31-828-1188

CLERK 1 Michie			
Kg	€/Kg	€	
FREE PRICE		#999999	
1.825Kg	2.22	2.28	



FREE PRICE	NONEIGHT	#999999
1x	28.88	28.88



Tomato		#123482
1.825Kg	1.99	2.84 C



TOTAL € 24.32

CASH		24.32
TAX GROUP	TAX	TTL
NO TAXABLE		22.28
C=15.88%	8.27	2.84
NUMBER OF SALES		3
07/02/2004 14:08:53		888846

Thank You!

Bye Bye



1828514824322



CAS KOREA

82-31-828-1188

CLERK 1 Michie			
Kg	€/Kg	€	
FREE PRICE		#999999	
1.825Kg	2.22	2.28	



FREE PRICE	NONEIGHT	#999999
1x	28.88	28.88



Tomato		#123482
1.825Kg	1.99	2.84 C



TOTAL € 24.32

CASH		24.32
TAX GROUP	TAX	TTL
NO TAXABLE		22.28
C=15.88%	8.27	2.84
NUMBER OF SALES		3
07/02/2004 12:08:18		888843

Thank You!

Bye Bye



CAS KOREA

82-31-828-1188

CLERK 1 Michie			
Kg	€/Kg	€	
FREE PRICE		#999999	
1.825Kg	2.22	2.28	
FREE PRICE	NONEIGHT	#999999	
1x	28.88	28.88	
Tomato		#123482	
1.825Kg	1.99	2.84 C	

TOTAL € 24.32

CASH		24.32
TAX GROUP	TAX	TTL
NO TAXABLE		22.28
C=15.88%	8.27	2.84
NUMBER OF SALES		3
07/02/2004 12:07:18		888844

Thank You!

Bye Bye



1828514824322

NO Barcode Printing



CAS KOREA

82-31-828-1188

CLERK 1 Michie			
Kg	€/Kg	€	
FREE PRICE		#999999	
1.825Kg	2.22	2.28	
FREE PRICE	NONEIGHT	#999999	
1x	28.88	28.88	
Tomato		#123482	
1.825Kg	1.99	2.84 C	





TOTAL € 24.32

CASH		24.32
TAX GROUP	TAX	TTL
NO TAXABLE		22.28
C=15.88%	8.27	2.84
NUMBER OF SALES		3
07/02/2004 12:08:05		888845

Thank You!

Bye Bye

e. Obligatory payment





- ① (Using  key and  go to *option setting mode* from main menu. And then press )
 to get into *obligatory payment option mode*.



- ② User may select YES or NO by pressing "1" or "0" respectively, and press  to save it.



f. Discount





- ① (Using  key and  go to *option setting mode* from main menu. And then press )
 to get into *discount option mode*.

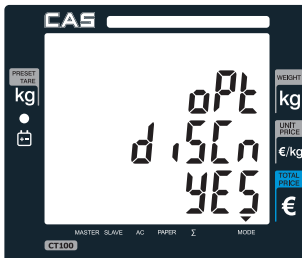



- ② User may select YES or NO by pressing "1" or "0" respectively, and press  to save it.

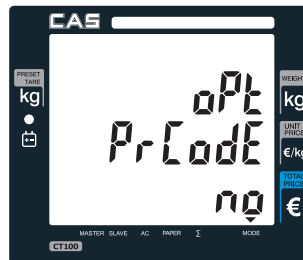

g. Printing PLU code

- ① (Using  key and  go to *option setting mode* from main menu. And then press )
 to get into *PLU code printing mode*.





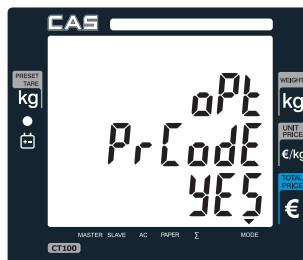

- ② User may select YES or NO by pressing "1" or "0" respectively, and press  to save it.



h. Printing all reports

- Select "YES" for all reports printed or "No" for only closing without other reports when executing "close".





- ① (Using  key and  go to *option setting mode* from main menu. And then press )
 to get into *all report printing mode*.

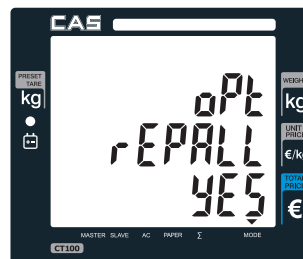



- ② User may select YES or NO by pressing "1" or "0" respectively, and press  to save it.



i. Printing tax

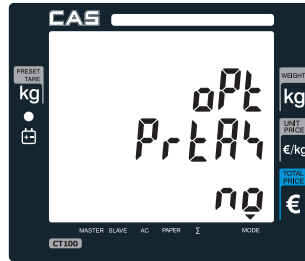



- ① (Using  key and  go to *option setting mode* from main menu. And then press )
 to get into *tax printing mode*.



- ② User may select YES or NO by pressing "1" or "0" respectively, and press  to save it.



j. Use back light





- ① (Using  key and  go to *option setting mode* from main menu. And then press )
 to get into *back light setting mode*.





- ② User may select YES or NO by pressing "1" or "0" respectively, and press  to save it.

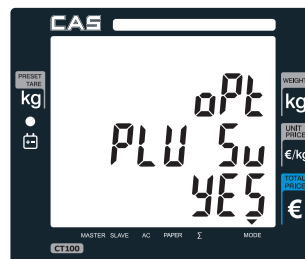

k. Saving PLU

- ① (Using  key and  go to *option setting mode* from main menu. And then press )
 to get into *PLU saving mode*.



- ② User may select YES or NO by pressing "1" or "0" respectively, and press  to save it.

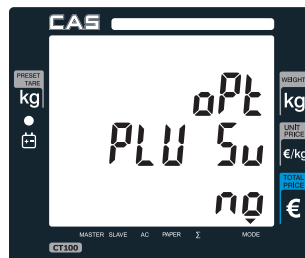

Chapter 12. CLERK



This chapter explains what kind of clerk modes there are and how different they are. In addition, it shows how to input name of clerk 1~8.

a. Clerk mode

There are three different type of clerk modes. **max number of sales per CLERK : 99**

Table 3 : Clerk Mode

Modes	Description	Receipt Printing
0	All clerks can use the scale for a series of sales activity.	It prints ticket (receipt) including each item and total information.
1	Only one clerk can use the scale for a series of sales activity. However, other clerk can use the scale for other series of sales activities in this mode.	It prints only part of ticket (receipt), which a transaction is made, and prints total amount after a series of transactions are completed.
2 (Supermarket mode)	Only one transaction per clerk at a moment.	It prints Label (receipt) only for one transaction per clerk.
3 (Label-1 Mode)	Only one transaction per clerk at a moment.	It prints Label (receipt) only for one transaction per clerk.
4 (Label-2 Mode)	Only one transaction per clerk at a moment.	Using key and go to clerk setting mode from main menu.



- ① Using  key and  go to *clerk setting mode* from main menu.





- ② User may select one of three clerk modes, "0", "1", or "2" by inputting appropriate numeric key. For example, "0" here. Then, save it by pressig .

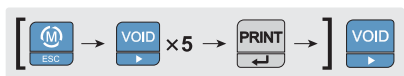

b. Clerk name input: 1~8

- ① (Using  key and ,  go to *clerk name setting mode* from main menu.



- ② Press  to get into *clerk name 1 setting* mode. User may input up to 16 characters in accordance to "code table" on page 105. For example, lets input "John Kim" as clerk name 1.

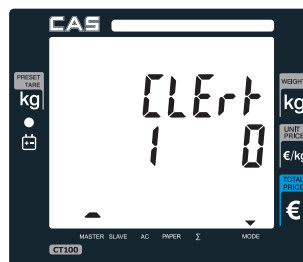

- ③ Input clerk' name using appropriate numeric keys in accordance to "code table" on page 105.

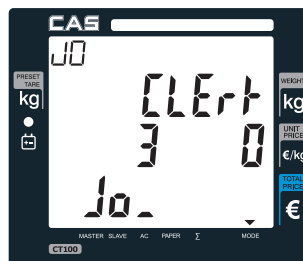
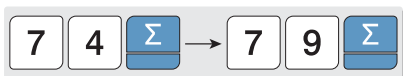

- ④ Input clerk' name using appropriate numeric keys in accordance to "code table" on page 105.

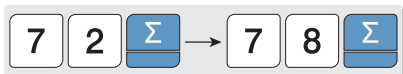

- ⑤ Input clerk' name using appropriate numeric keys in accordance to "code table" on page 105.

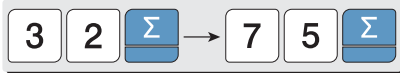

- ⑥ Input clerk' name using appropriate numeric keys in accordance to "code table" on page 105.

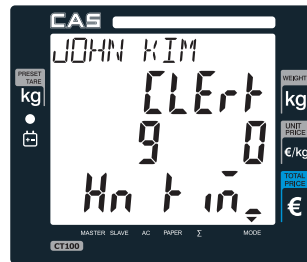
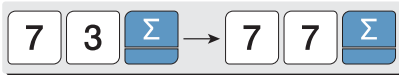

- ⑦ After finishing clerk name input save it by pressing  .





- * Whenever user wants to go back to main menu use .
- * User may input other clerk names as above up to 4 names.

Chapter 13. LOGO

This chapter explains how to input header and footer on the ticket (receipt). Users may input up to **6 header** and **2 footer lines**, which each line may have **up to 32 characters**, using "code table" on 105 page.

a. Header & Footer setting

- ① Using  key and ,  go to *Logo setting mode* from main menu.



- ② Press  to get into Headline 1 setting mode.



- ③ Press  and input appropriate numeric keys to input codes in the headline 1 (refer to page 105). For example, lets input "CAS" at 16th space in the first headline.

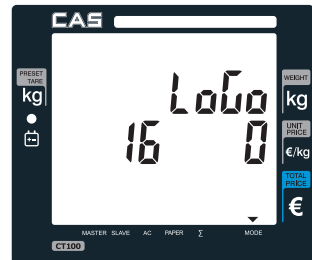

④ Press appropriate numeric keys.

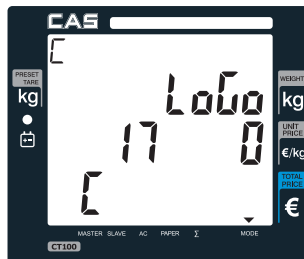

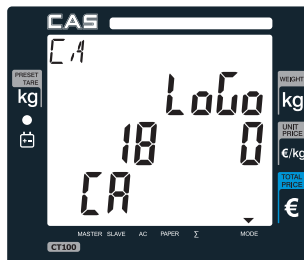

⑤ Press appropriate numeric keys.

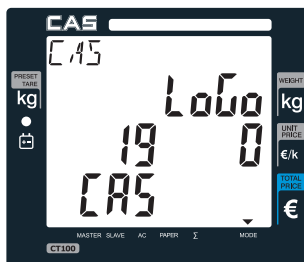
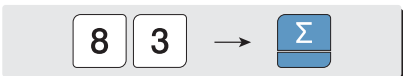

⑥ Press appropriate numeric keys.





⑦ Press  to save the first headline. And user may press  to go to input next headline (*storable up to 6 header & 2 footer lines*), and exit using .



Chapter 14. TAX RATE GROUP

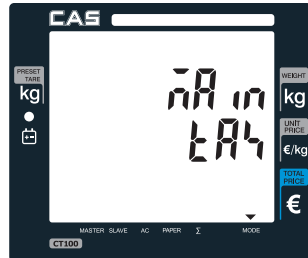

This chapter explains how to set tax rate group. User may set up to **8 different tax rate groups: A, B, C, D, E, F, G, H**, and then store a specific tax group when he/she inputs PLU data.

- ① Using  key and ,  go to *tax rate group setting mode* from main menu.



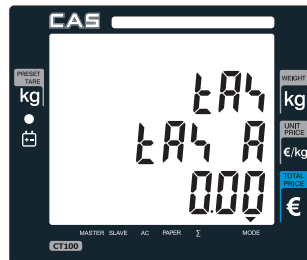

- ② Press  to get into *tax rate group A setting mode*.

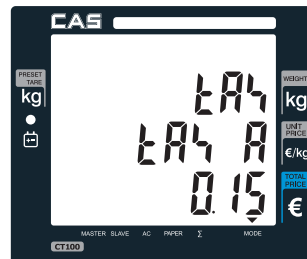

- ③ Press appropriate numeric keys (0.00~99.99%) to input tax rate for group A. For example, press   input "0.15%" for tax rate group A, and  to save it.



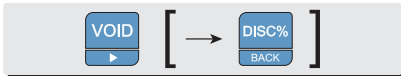

④ User may press  to go to input next tax rate group, B. Press  .





Chapter 15. TEST

This chapter explains how to test hardware in the following aspects.



- ADC (Analog Digital Converter): the digital value converted from analogvalue.
- SPAN
- Display : self-test
- Keyboard
- Memory
- Printer : self-test
- Battery Voltage : tested only in *unplugged condition*, showing voltage value.

① Using  key and  ,  go to *test setting mode* from main menu.



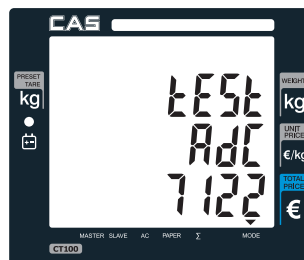
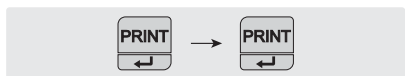



② Press  to get into *ADC test mode*. Then press  again to show current ADC value.

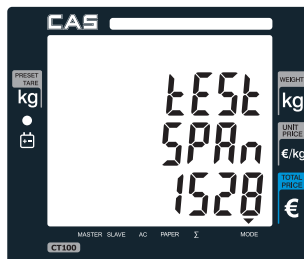

③ After making sure the ADC value press  (or ) to get back to *ADC test mode*. Then press  again to go to next test mode, *SPAN test mode*.



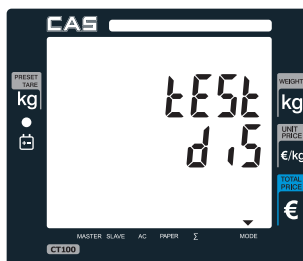
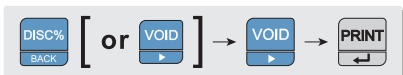

- ④ After making sure the SPAN value press

 (or ) to get back to *SPAN test mode* and press  again to go to next *Display test mode*. Then test display automatically by pressing .



- ⑤ Press  go to next *Keyboard test mode*.

In this mode user may press any key and a specific number (ex. 104 ) comes up on total price display (first line of display) except  because  is used for exit out of current mode.

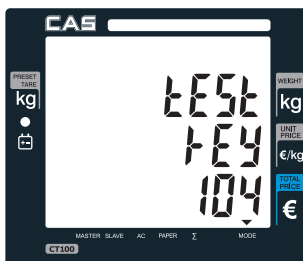

- ⑥ Press  to go to *Memory test mode*.

Then press  to test. Display will show either "PASS" or "Error" in a few second. Please refer to "Table 15:Error Messages" on page 115 when "Error" comes up.

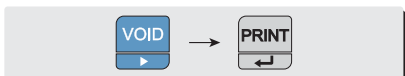

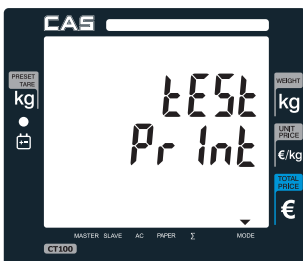

- ⑦ Press  to go to *Printer self-test mode*.

Then, press  to test the printer and show current voltage on the display.

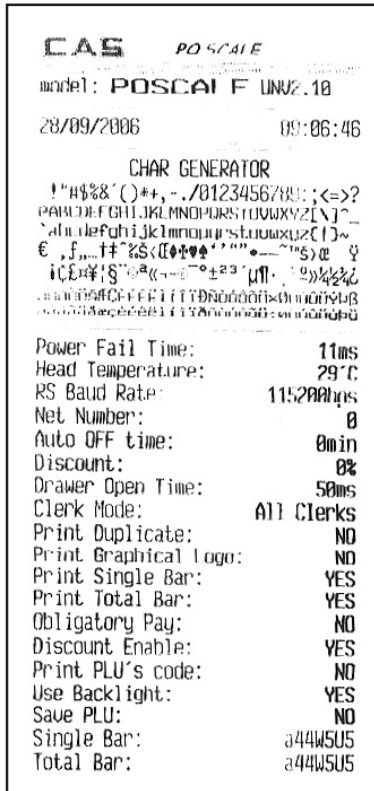



- ⑧ Press  to go to **Battery voltage mode**.
 Then, press  to see current voltage. Please keep in mind that the scale must be **unplugged** to show current voltage.

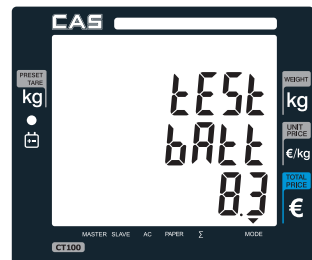

CODE [MS 1250 Windows Central Europe]

Table 8 : Code [MS 1250 Windows Central Europe]

33	34	35	36	37	38	39	40	41	42	43	44	45	46	47	48
!	"	#	\$	%	&	'	()	*	+	,	-	.	/	0
49	50	51	52	53	54	55	56	57	58	59	60	61	62	63	64
1	2	3	4	5	6	7	8	9	:	;	<	=	>	?	@
65	66	67	68	69	70	71	72	73	74	75	76	77	78	79	80
A	B	C	D	E	F	G	H	I	J	K	L	M	N	O	P
81	82	83	84	85	86	87	88	89	90	91	92	93	94	95	96
Q	R	S	T	U	V	W	X	Y	Z	[\]	^	_	`
97	98	99	100	101	102	103	104	105	106	107	108	109	110	111	112
a	b	c	d	e	f	g	h	i	j	k	l	m	n	o	p
113	114	115	116	117	118	119	120	121	122	123	124	125	126	127	128
q	r	s	t	u	v	w	x	y	z	{		}	~	□	€
129	130	131	132	133	134	135	136	137	138	139	140	141	142	143	144
∅	'	∅	„	…	†	‡	∅	‰	§	◀	§	†	‡	§	∅
145	146	147	148	149	150	151	152	153	154	155	156	157	158	159	160
'	„	“	”	•	—	—	∅	™	§	›	§	†	‡	§	
161	162	163	164	165	166	167	168	169	170	171	172	173	174	175	176
˘	˘	ł	▣	Å	ı	§	¨	©	§	«	¬	-	®	Ž	°
177	178	179	180	181	182	183	184	185	186	187	188	189	190	191	192
±		ı	'	μ	¶	·		ą	§	»	Ł	˘	ı	ż	Ŕ
193	194	195	196	197	198	199	200	201	202	203	204	205	206	207	208
Á	Â	Ã	Ä	Å	Ĺ	Ć	Ç	Č	É	Ę	Ě	Ě	Í	Ī	Ď
209	210	211	212	213	214	215	216	217	218	219	220	221	222	223	224
Ń	Ň	Ó	Ô	Õ	Ö	×	Ř	Ú	Ů	Ů	Ů	Ů	Ý	Ť	Ř
225	226	227	228	229	230	231	232	233	234	235	236	237	238	239	240
á	â	ã	ä	å	ĺ	ć	ç	č	é	ę	ě	ě	í	î	ď
241	242	243	244	245	246	247	248	249	250	251	252	253	254	255	
ń	ň	ó	ô	õ	ö	÷	ř	ú	ů	ů	ů	ů	ý	ť	·

Code [MS 1251 Windows Cyrillic(Slavic)]

Table 9: Code [MS 1251 Windows Cyrillic(Slavic)]

33	34	35	36	37	38	39	40	41	42	43	44	45	46	47	48
!	"	#	\$	%	&	'	()	*	+	,	-	.	/	0
49	50	51	52	53	54	55	56	57	58	59	60	61	62	63	64
1	2	3	4	5	6	7	8	9	:	;	<	=	>	?	@
65	66	67	68	69	70	71	72	73	74	75	76	77	78	79	80
A	B	C	D	E	F	G	H	I	J	K	L	M	N	O	P
81	82	83	84	85	86	87	88	89	90	91	92	93	94	95	96
Q	R	S	T	U	V	W	X	Y	Z	[\]	^	_	`
97	98	99	100	101	102	103	104	105	106	107	108	109	110	111	112
a	b	c	d	e	f	g	h	i	j	k	l	m	n	o	p
113	114	115	116	117	118	119	120	121	122	123	124	125	126	127	128
q	r	s	t	u	v	w	x	y	z	{		}	~	▯	Ђ
129	130	131	132	133	134	135	136	137	138	139	140	141	142	143	144
ѓ	'	ѓ	„	…	†	‡	€	‰	Љ	‹	Њ	ќ	ћ	џ	ђ
145	146	147	148	149	150	151	152	153	154	155	156	157	158	159	160
'	'	“	”	•	–	—	▯	™	љ	›	њ	ќ	ћ	џ	
161	162	163	164	165	166	167	168	169	170	171	172	173	174	175	176
Ў	ў	Ј	Ѡ	Ґ	Ҁ	§	Є	©	Є	«	¬	-	®	і	°
177	178	179	180	181	182	183	184	185	186	187	188	189	190	191	192
±	І	і	Ҁ	μ	¶	·	ё	№	є	»	ј	Ѕ	ѕ	ї	А
193	194	195	196	197	198	199	200	201	202	203	204	205	206	207	208
Б	В	Г	Д	Е	Ж	З	И	Й	К	Л	М	Н	О	П	Р
209	210	211	212	213	214	215	216	217	218	219	220	221	222	223	224
С	Т	У	Ф	Х	Ц	Ч	Ш	Щ	Ъ	Ы	Ь	Э	Ю	Я	а
225	226	227	228	229	230	231	232	233	234	235	236	237	238	239	240
б	в	г	д	е	ж	з	и	й	к	л	м	н	о	п	р
241	242	243	244	245	246	247	248	249	250	251	252	253	254	255	
с	т	у	ф	х	ц	ч	ш	щ	ъ	ы	ь	э	ю	я	

Code [MS 1252 Windows Latin-1]

Table 10 : Code [MS 1252 Windows Latin-1]

33	34	35	36	37	38	39	40	41	42	43	44	45	46	47	48
!	"	#	\$	%	&	'	()	*	+	,	-	.	/	0
49	50	51	52	53	54	55	56	57	58	59	60	61	62	63	64
1	2	3	4	5	6	7	8	9	:	;	<	=	>	?	@
65	66	67	68	69	70	71	72	73	74	75	76	77	78	79	80
A	B	C	D	E	F	G	H	I	J	K	L	M	N	O	P
81	82	83	84	85	86	87	88	89	90	91	92	93	94	95	96
Q	R	S	T	U	V	W	X	Y	Z	[\]	^	_	`
97	98	99	100	101	102	103	104	105	106	107	108	109	110	111	112
a	b	c	d	e	f	g	h	i	j	k	l	m	n	o	p
113	114	115	116	117	118	119	120	121	122	123	124	125	126	127	128
q	r	s	t	u	v	w	x	y	z	{		}	~	□	€
129	130	131	132	133	134	135	136	137	138	139	140	141	142	143	144
ı	'	f	"	...	†	‡	^	‰	Š	<	Œ	ı	Ž	ı	ı
145	146	147	148	149	150	151	152	153	154	155	156	157	158	159	160
'	'	"	"	*	—	—	~	™	š	>	œ	ı	ž	ÿ	
161	162	163	164	165	166	167	168	169	170	171	172	173	174	175	176
ı	¢	£	¤	¥	ı	§	¨	©	ª	«	¬	-	®	¯	°
177	178	179	180	181	182	183	184	185	186	187	188	189	190	191	192
±	²	³	´	µ	¶	·	¸	¹	º	»	¼	½	¾	¿	À
193	194	195	196	197	198	199	200	201	202	203	204	205	206	207	208
Á	Â	Ã	Ä	Å	Æ	Ç	È	É	Ê	Ë	Ì	Í	Î	Ï	Ð
209	210	211	212	213	214	215	216	217	218	219	220	221	222	223	224
Ñ	Ò	Ó	Ô	Õ	Ö	×	Ø	Ù	Ú	Û	Ü	Ý	Þ	ß	à
225	226	227	228	229	230	231	232	233	234	235	236	237	238	239	240
á	â	ã	ä	å	æ	ç	è	é	ê	ë	ì	í	î	ï	ð
241	242	243	244	245	246	247	248	249	250	251	252	253	254	255	
ñ	ò	ó	ô	õ	ö	÷	ø	ù	ú	û	ü	ý	þ	ÿ	

Code [MS 1253 Windows Greek]

Table 11 : Code [MS 1253 Windows Greek]

33	34	35	36	37	38	39	40	41	42	43	44	45	46	47	48
!	"	#	\$	%	&	'	()	*	+	,	-	.	/	0
49	50	51	52	53	54	55	56	57	58	59	60	61	62	63	64
1	2	3	4	5	6	7	8	9	:	;	<	=	>	?	@
65	66	67	68	69	70	71	72	73	74	75	76	77	78	79	80
A	B	C	D	E	F	G	H	I	J	K	L	M	N	O	P
81	82	83	84	85	86	87	88	89	90	91	92	93	94	95	96
Q	R	S	T	U	V	W	X	Y	Z	[\]	^	_	`
97	98	99	100	101	102	103	104	105	106	107	108	109	110	111	112
a	b	c	d	e	f	g	h	i	j	k	l	m	n	o	p
113	114	115	116	117	118	119	120	121	122	123	124	125	126	127	128
q	r	s	t	u	v	w	x	y	z	{		}	~	□	€
129	130	131	132	133	134	135	136	137	138	139	140	141	142	143	144
∏	'	f	„	…	†	‡	∅	‰	∂	<	∅	∅	∅	∅	∅
145	146	147	148	149	150	151	152	153	154	155	156	157	158	159	160
'	'	“	”	•	—	—	∅	™	∅	>	∅	∅	∅	∅	∅
161	162	163	164	165	166	167	168	169	170	171	172	173	174	175	176
ˆ	À	£	¤	¥	¦	§	¨	©	∅	«	¬	-	®	—	°
177	178	179	180	181	182	183	184	185	186	187	188	189	190	191	192
±	²	³	´	µ	¶	·	È	É	Ì	»	Ò	½	Υ	Ω	Ï
193	194	195	196	197	198	199	200	201	202	203	204	205	206	207	208
A	B	Γ	Δ	E	Z	H	Θ	I	K	Λ	M	N	Ξ	O	Π
209	210	211	212	213	214	215	216	217	218	219	220	221	222	223	224
P	∅	Σ	T	Υ	Φ	X	Ψ	Ω	Ï	ÿ	ά	έ	ή	ί	ü
225	226	227	228	229	230	231	232	233	234	235	236	237	238	239	240
α	β	γ	δ	ε	ζ	η	θ	ι	κ	λ	μ	ν	ξ	ο	π
241	242	243	244	245	246	247	248	249	250	251	252	253	254	255	
ρ	ς	σ	τ	υ	φ	χ	ψ	ω	ÿ	ÿ	ό	ύ	ώ		

Code [MS 1254 Windows Turkish]

Table 12 : Code [MS 1254 Windows Turkish]

33	34	35	36	37	38	39	40	41	42	43	44	45	46	47	48
!	"	#	\$	%	&	'	()	*	+	,	-	.	/	0
49	50	51	52	53	54	55	56	57	58	59	60	61	62	63	64
1	2	3	4	5	6	7	8	9	:	;	<	=	>	?	@
65	66	67	68	69	70	71	72	73	74	75	76	77	78	79	80
A	B	C	D	E	F	G	H	I	J	K	L	M	N	O	P
81	82	83	84	85	86	87	88	89	90	91	92	93	94	95	96
Q	R	S	T	U	V	W	X	Y	Z	[\]	^	_	`
97	98	99	100	101	102	103	104	105	106	107	108	109	110	111	112
a	b	c	d	e	f	g	h	i	j	k	l	m	n	o	p
113	114	115	116	117	118	119	120	121	122	123	124	125	126	127	128
q	r	s	t	u	v	w	x	y	z	{		}	~	□	€
129	130	131	132	133	134	135	136	137	138	139	140	141	142	143	144
ı	'	f	"	...	†	‡	^	‰	Š	<	Œ	▯	▯	▯	▯
145	146	147	148	149	150	151	152	153	154	155	156	157	158	159	160
'	'	"	"	*	-	—	~	™	š	>	œ	▯	▯	ÿ	
161	162	163	164	165	166	167	168	169	170	171	172	173	174	175	176
j	ç	£	¤	¥	ı	§	¨	©	ª	«	¬	-	®	¯	°
177	178	179	180	181	182	183	184	185	186	187	188	189	190	191	192
±	²	³	´	µ	¶	·	¸	¹	º	»	¼	½	¾	¿	À
193	194	195	196	197	198	199	200	201	202	203	204	205	206	207	208
Á	Â	Ã	Ä	Å	Æ	Ç	È	É	Ê	Ë	Ì	Í	Î	Ï	Ğ
209	210	211	212	213	214	215	216	217	218	219	220	221	222	223	224
Ñ	Ò	Ó	Ô	Õ	Ö	×	Ø	Ù	Ú	Û	Ü	Ý	Ş	ß	à
225	226	227	228	229	230	231	232	233	234	235	236	237	238	239	240
á	â	ã	ä	å	æ	ç	è	é	ê	ë	ì	í	î	ï	ğ
241	242	243	244	245	246	247	248	249	250	251	252	253	254	255	
ñ	ò	ó	ô	õ	ö	÷	ø	ù	ú	û	ü	ı	ş	ý	

Code [MS 1257 Windows Baltic]

Table 13 : Code [MS 1257 Windows Baltic]

33	34	35	36	37	38	39	40	41	42	43	44	45	46	47	48
!	"	#	\$	%	&	'	()	*	+	,	-	.	/	0
49	50	51	52	53	54	55	56	57	58	59	60	61	62	63	64
1	2	3	4	5	6	7	8	9	:	;	<	=	>	?	@
65	66	67	68	69	70	71	72	73	74	75	76	77	78	79	80
A	B	C	D	E	F	G	H	I	J	K	L	M	N	O	P
81	82	83	84	85	86	87	88	89	90	91	92	93	94	95	96
Q	R	S	T	U	V	W	X	Y	Z	[\]	^	_	`
97	98	99	100	101	102	103	104	105	106	107	108	109	110	111	112
a	b	c	d	e	f	g	h	i	j	k	l	m	n	o	p
113	114	115	116	117	118	119	120	121	122	123	124	125	126	127	128
q	r	s	t	u	v	w	x	y	z	{		}	~	□	€
129	130	131	132	133	134	135	136	137	138	139	140	141	142	143	144
▯	'	▯	"	...	†	‡	▯	‰	▯	<	▯	"	˘	,	▯
145	146	147	148	149	150	151	152	153	154	155	156	157	158	159	160
'	'	"	"	•	—	—	▯	™	▯	>	▯	—	˘	▯	
161	162	163	164	165	166	167	168	169	170	171	172	173	174	175	176
	¢	£	¤		¦	§	Ø	©	®	«	¬	-	®	Æ	°
177	178	179	180	181	182	183	184	185	186	187	188	189	190	191	192
±	²	³	´	µ	¶	·	ø	¹	ƒ	»	¼	½	¾	æ	Å
193	194	195	196	197	198	199	200	201	202	203	204	205	206	207	208
ı	Ā	Ā	Ā	Ā	Ē	Ē	Ĉ	Ĉ	Ĉ	Ĝ	Ĝ	Ĩ	Ĩ	Š	Š
209	210	211	212	213	214	215	216	217	218	219	220	221	222	223	224
Ņ	Ņ	Ō	Ō	Ō	Ō	×	Ū	Ū	Š	Ū	Ū	Ž	Ž	ß	ą
225	226	227	228	229	230	231	232	233	234	235	236	237	238	239	240
ı	ā	ā	ā	ā	ē	ē	ĉ	ĉ	ĉ	ĝ	ĝ	ĥ	ĥ		š
241	242	243	244	245	246	247	248	249	250	251	252	253	254	255	
ņ	ņ	ō	ō	ō	ō	÷	ū	ū	š	ū	ū	ž	ž	·	

CODE [FARSI FONT (IRAN)]

Table 14 : Code [FARSI FONT (IRAN)]

33	34	35	36	37	38	39	40	41	42	43	44
!	"	#	\$	%	&	'	()	*	+	,
45	46	47	48	49	50	51	52	53	54	55	56
-	.	/	°	\	۲	۳	۴	۵	۶	۷	۸
57	58	59	60	61	62	63	64	65	66	67	68
۹	:	:	«	=	»	؟	-	آ	اَ	أ	ئ
69	70	71	72	73	74	75	76	77	78	79	80
۰	۱	۲	۱	۱	ب	ب	۰	ب	ب	ب	۰
81	82	83	84	85	86	87	88	89	90	91	92
پ	ن	ت	ت	ت	ن	ن	ت	ت	ج	ج	ز
93	94	95	96	97	98	99	100	101	102	103	104
ز	ح	ح	س	و	چ	چ	ز	ز	خ	خ	ن
105	106	107	108	109	110	111	112	113	114	115	116
خ	د	د	ن	ن	د	و	ز	ز	ث	ث	س
117	118	119	120	121	122	123	124	125	126	127	128
س	س	س	ش	ش	ش	ش	ص	ص	ص		
129	130	131	132	133	134	135	136	137	138	139	140
ع		ص	ض	ض	ض	ض	ط	ط	ط	ط	ظ
141	142	143	144	145	146	147	148	149	150	151	152
ظ				ظ	ظ	ع	ع	ع	ع	غ	غ
153	154	155	156	157	158	159	160	161	162	163	164
غ	غ	ف	ف	ف		ف	ق	ق	ق	ق	ک
165	166	167	168	169	170	171	172	173	174	175	176
ک	ک	ک	گ	گ	گ	د	ل	ل	لا	لا	ل
177	178	179	180	181	182	183	184	185	186	187	188
ل	م	م	م	م	ن	ن	ن	و	و	و	
189	190	191	192	193	194	195	196	197	198	199	200
۰	۰	۰	ی	ی	۰	۰	۰	۰	۰	۰	۰
201	۰										

ERROR MESSAGES

Table 15 : Error Messages

Error Message on Display	Description	Solution
TOO HOT	Printer is overheated.	Please take time to cool off the printer.
BATTERY LOW ERROR	Battery voltage is too low	Please plug in and recharge battery
PAPER	Problem with ticket paper roll	Please check paper
-----	Overloaded	Please remove the item from the platter and put only appropriately weighed item(s) on the platter
Over	When total price exceeds 9999.99 this message is displayed with beep	Please input appropriate number within maximum capacity on the display.
CAL ERROR	When turning on the scale this message may be displayed with continuous beep and it is automatically turned off.	Please call your CAS dealer.
INIT ERROR		Please remove the item from the platter and put only appropriately weighed item(s) on the platter.
Error Message on Receipt	Description	Solution
CLOCK IS NOT SET	This error may happen in case of low backup battery or some hardware error!	Please call your CAS dealer when there is still error after setting DATE & TIME in MENU -> SET2.
ERROR POSSIBLE RAM DATA ARE CORRUPTED! RESETTING ALL RAM DATA. PLEASE RESTART THE SCALE	This message is printed when the control sums of RAM is not correct. In such case the processor clears the RAM automatically. And all of sums, settings and PLU are deleted!	Please call your CAS dealer

SPECIFICATION

What beep sound means..

- **Short beep:** key is pressed.
- **Middle length beep:** some information event (for example, power on)
- **Long beep:** successive event (for example, adding sale to clerk)
- **Five times fast short beeps:** error! (Wrong key, wrong data input...)

Table 16 : SPECIFICATION

Model		CT100							
CAPACITY		6kg		15kg			30kg		
Division, e=		1/2g	2g	2g	2/5g	5g	5g	5/10g	10g
Minimum weight ※		20g	40g	40g	40g	100g	100g	100g	200g
DISPLAY		LCD, 6/6/5 (Total price / Unit Price / Weight)							
EMBEDDED PRINTER INFO.		<ul style="list-style-type: none"> ■ Thermal printer - 32 Characters per line ■ Printing Speed- <ul style="list-style-type: none"> Dark 1 & AC POWER : 50mm/sec Dark 5 & AC POWER : 35mm/sec Dark 1 & DC(8.4V) : 44mm/sec Dark 5 & DC(8.4V) : 28mm/sec ■ Recommended size for thermal paper ; <ul style="list-style-type: none"> • 58mm (Width) / 65 (Thickness) / 60mm (Maximum Diameter) 							
PRINTER RELIABILITY	HEAD PULSE-RESISTANCE	100,000,000 pulses or more							
	HEAD WEAR-RESISTANCE	50km or more							
PLU MEMORY CAPACITY		30 Direct PLUs, 1,000 Indirect PLUs, 2 Special PLUs							
POWER		AC 230V, 50 ~ 60Hz							
OPERATING TEMPERATURE		-10℃ ~ +40℃							
EXTERNAL UTILITIES		PC, Cash Drawer (12 volts)							
POWER CONSUMPTION		Maximum 35W							
BATTERY LIFE		<ul style="list-style-type: none"> ■ Rechargeable Battery (inside): 12V 5Ah (Pb) ■ Battery life (continuous usage) <ul style="list-style-type: none"> • Weighing Mode only : 73mA, 28 hrs • Battery Option: 7.4V 4Ah(Li-ion) • With backlight : 170mA, 12 hrs • With printer : 1300mA, 1.5 hrs 							
SCALE SIZE (mm)		Standard type : 375(W) X 397(D) X 128(H) Pole type : 375(W) X 433(D) X 436(H)							
PRODUCT WEIGHT		Standard type : 6.8Kg Pole type : 8Kg							

※ **Minimum weight to make a sale transaction**

▶ Notice: specifications are subject to change for improvement without notice.

Table List

	page
Table 1: Symbols on display.....	9
Table 2: Key Functions.....	10
Table 3: Clerk Mode.....	26 & 92
Table 4: Most commonly used keys program mode.....	54
Table 5: PLU Programming.....	56
Table 6: "C" key operation while printing.....	62
Table 7: SET1.....	68
Table 8: Code [MS 1250 Window Central Europe].....	105
Table 9: Code [MS 1251 Window Cyrillic(Slavic)].....	106
Table 10: Code [MS 1252 Window Latin-1].....	107
Table 11: Code [MS 1253 Window Greek].....	108
Table 12: Code [MS 1254 Window Turkish].....	109
Table 13: Code [MS 1257 Window Baltic].....	110
Table 14: Code [FARSI FONT(IRAN)].....	111
Table 15: Error Messages.....	112
Table 16: Specifications.....	113
Table 17: Program Menu Map.....	116

Cash Drawer Interface Drawing

■ POScale may interface only with 12V cash drawer.

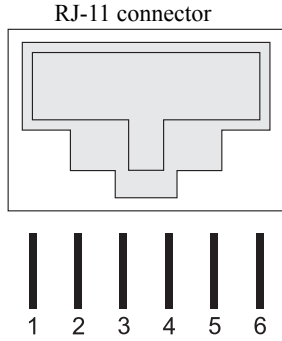

Not connected : 1 x
 (+12V) : 2
 Ground : 3
 Ground : 4
 (+ 12V) : 5

Not connected : 6 x

RS232C Interface Drawing

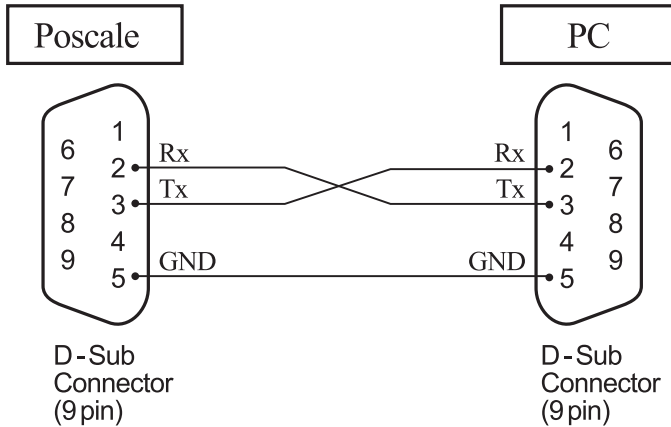

PROGRAM MENU MAP

Table 17 : PROGRAM MENU MAP

Mode	Sub-Mode	Menu	On Display	Page
Mode	PLU (CHAPTER 7)	Validity	vALid	57
		Price	PrICE	57
		Code	CodE	57
		Departmet	dEP	58
		Name	nAME	58
		Tax rate group A~H	tAX	59
		Weighed or non-weighted?	no W	59
		Fixed or non-fixed unit price?	FIX Pr	59
		Barcode printing?	Pr bAr	59
	Report (CHAPTER 8)	PLU data list	LiSt	61
		PLU report	PLU	62
		Clerk report	CLERK	64
		Department report	dEP	65
		Tax report	TAX	66
		Hourly sales report	HoUr	66
		Closing report	CLoSE	66
	SET 1 (CHAPTER 9)	BAUD rate	bAUd	68
		Auto power-off	AUtoo	69
		Discount percentage ("Pr-" on display)	PrbAr	69
		Barcode format for a single transaction	bar S	70
		Barcode format for subtotal	bAr t	75
		Pulse length of opening cash drawer	dro Y	76
		(Printing) Darkness (default setting: 3)	dAr K	76
	Currency symbol or name	CUrr	77	
	SET 2 (CHAPTER 10)	Date	dAtE	79
		Time	tIME	80
		One touch PLU data Erasing	Er PLU	80
		Default setting	dEFAUL	81

Continued on next page

Mode	Options (CHAPTER 11)	Duplicate receipt?	dbl	83
		Image(Graphic Logo)	iMAGE	84
		Printing barcode for a single transaction on receipt?	bAr S	85
		Printing barcode for total on receipt?	bAr t	85
		Obligatory payment?	ob PAY	87
		Discount?	diSCn	87
		Printing PLU code?	Pr CodE	88
		Printing all reports?	rEPALL	88
		Printing Tax?	PrTAX	89
		Use Back Light ?	Light	89
	Saving PLU ?	PLU Sv	90	
Mode	Clerk (CHAPTER 12)	Clerk Mode 0, 1, 2, 3, 4, ?	ModE	92
		Name 1	nAME1	93
		Name 2	nAME2	93
		Name 3	nAME3	93
		Name 4	nAME4	93
	Logo (CHAPTER 13)	Header line 1	HLinE1	96
		Header line 2	HLinE2	96
		Header line 3	HLinE3	96
		Header line 4	HLinE4	96
		Header line 5	HLinE5	96
		Header line 6	HLinE6	96
		Footer line 1	FinE 1	96
		Footer line 2	FinE 2	96
	Tax Rate Group (CHAPTER 14)	Group A	tAXA	99
		Group B	tAX B	99
		Group C	tAX C	99
		Group D	tAX D	99
		Group E	tAX E	99
		Group F	tAX F	99
		Group G	tAX G	99
		Group H	tAX H	99
	TEST (CHAPTER 15)	ADC	AdC	102
		SAPN	SPAn	102
		Display	diS	103
		Keyboard	KEY	103
		RAM	rAM	103
		Printer	Print	103
Battery voltage		bAtt	104	

MEMO

MEMO





MEMO



CT100

Ticket Printing Scale



CAS BLDG., # 440-1, SUNGNAE-DONG,
GANGDONG-GU, SEOUL, KOREA
TEL_ 82 2 2225 3500
FAX_ 82 2 475 4668
www.globalcas.com